

ASSEMBLY INSTRUCTION

PLEASE READ BEFORE ASSEMBLING!

Tip #1: Make sure you've taken all the pieces and hardware out of its packaging before discarding the box. Assembly on top of flattened box/blanket is recommended.

Tip #2: Using page 2 and/or page 3 of instruction manual make sure all pieces and hardware are accounted for.

Tip #3: Note position of all holes on each panel during assembly.

ITEM#: 161620 M202756

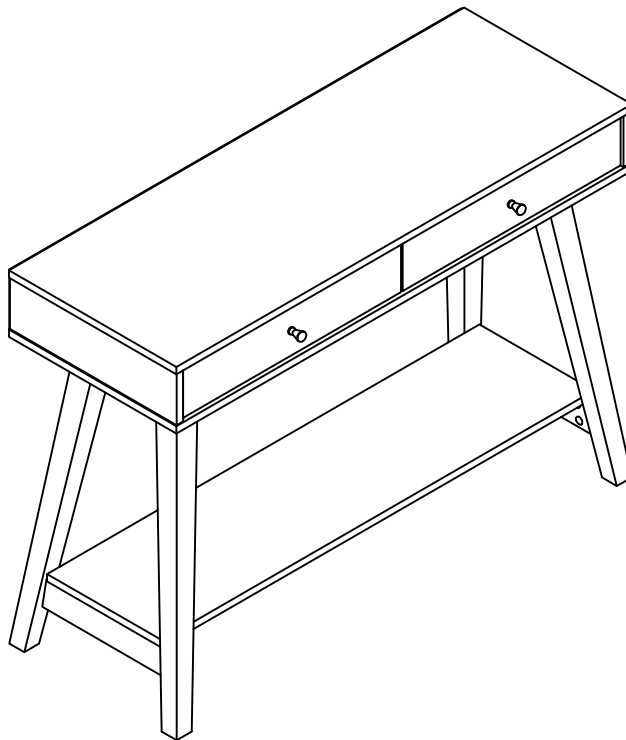

PARTS IDENTIFICATION



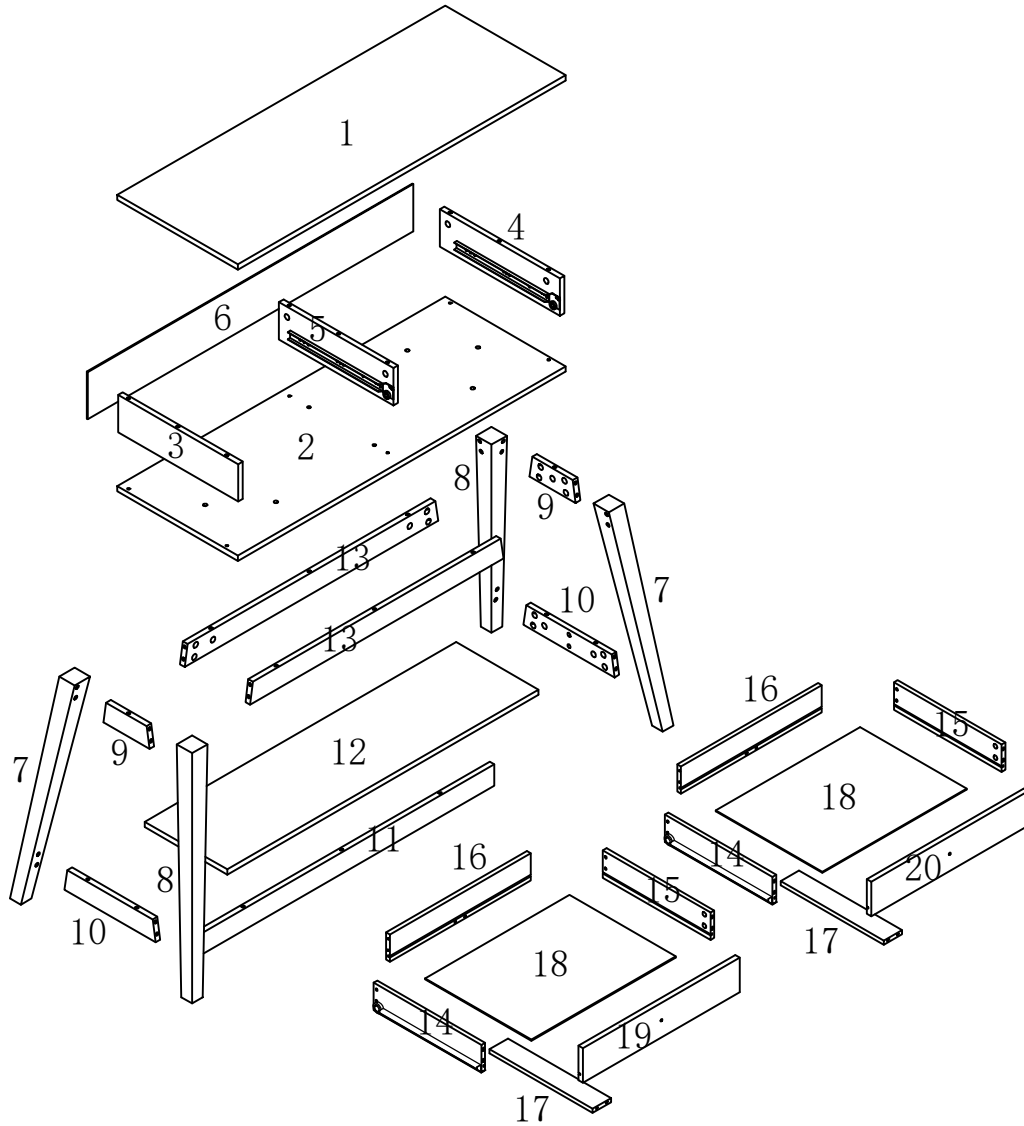







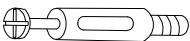

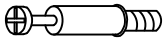

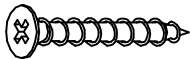

ITEM#: 161620 M202756

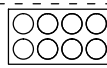

(1)	1pc	(8)	2pcs	(15)	2pcs
(2)	1pc	(9)	2pcs	(16)	2pcs
(3)	1pc	(10)	2pcs	(17)	2pcs
(4)	1pc	(11)	1pc	(18)	2pcs
(5)	1pc	(12)	1pc	(19)	1pc
(6)	1pc	(13)	2pcs	(20)	1pc
(7)	2pcs	(14)	2pcs		

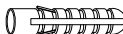

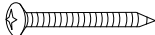
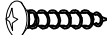
HARDWARE IDENTIFICATION

ITEM#: 161620 M202756

A		L29	46pcs
B		15	46pcs
C		L20	8pcs
D		12	8pcs
E		8 x 25	9pcs
F		6 x 30	4pcs
G		4 x 30	18pcs
H			2pcs
I		M4 x 22	2pcs
J		Z1016	22pcs
K		20	34pcs
L		16	4pcs
M		197x5x1	1pc
N		∅8x40	1pc
O		12x12x1	2pcs
P		∅5x40	1pc
Q		∅4x25	1pc
R		Glue: For securing please apply to wood dowel first before inserting into panel	1pc

ASSEMBLY INSTRUCTION

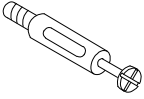
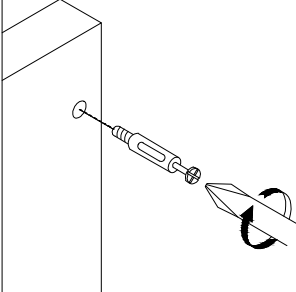
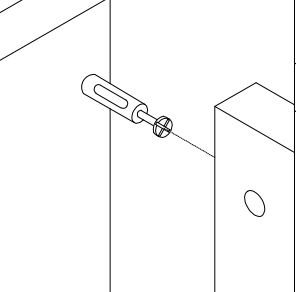
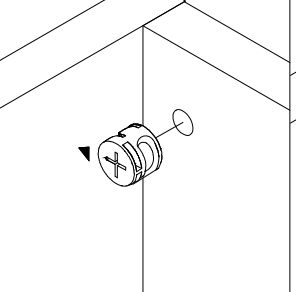
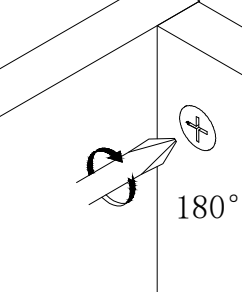
ITEM#: 161620 M202756

HOW TO	1	2	3	4
 Cam Bolt				
 Cam Lock	1. Screw Cam Bolt into panel.	2. Insert Cam Bolt into bolt hole of joining panel.	3. Insert Cam Lock. arrow facing bolt.	4. Gently turn Cam Lock clockwise to lock position.

STEP1

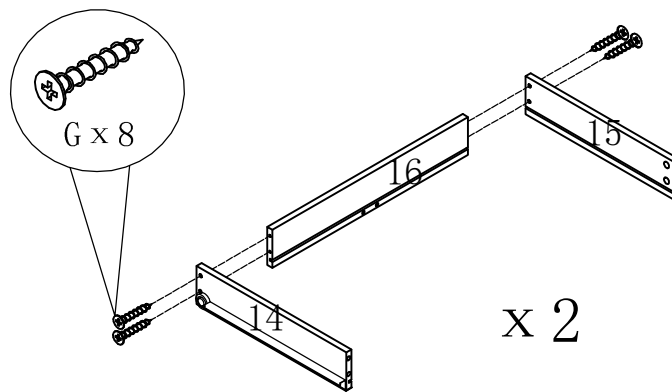

ASSEMBLY INSTRUCTION

ITEM#: 161620 M202756

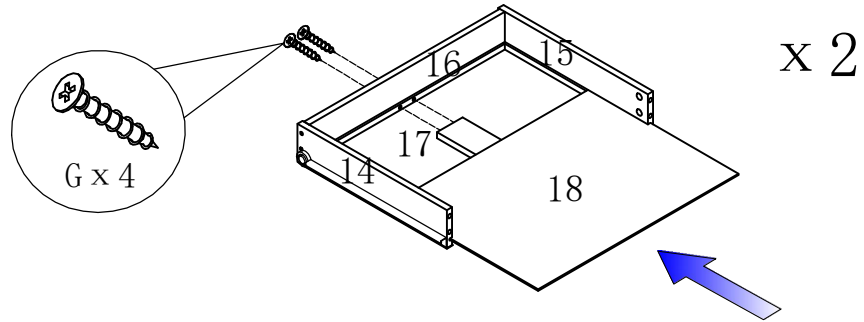

STEP2

STEP3

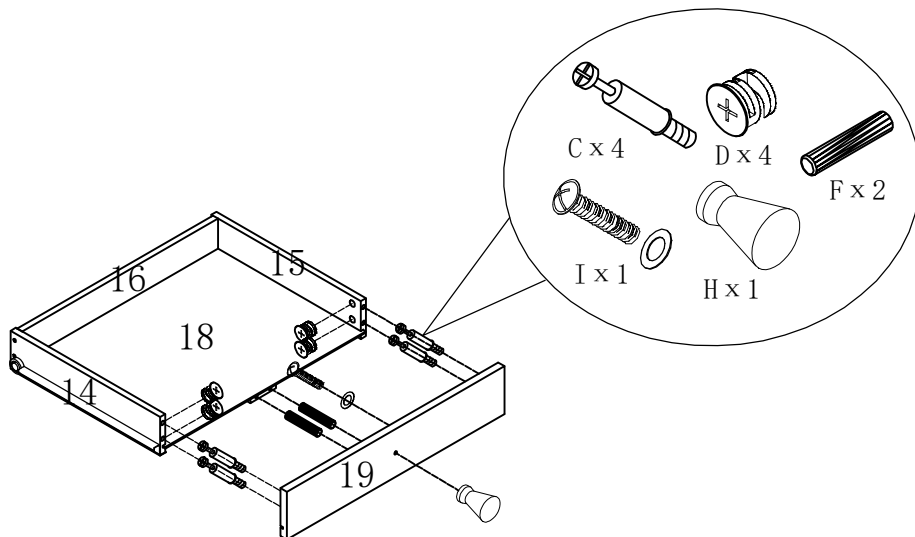

ASSEMBLY INSTRUCTION

ITEM#: 161620 M202756

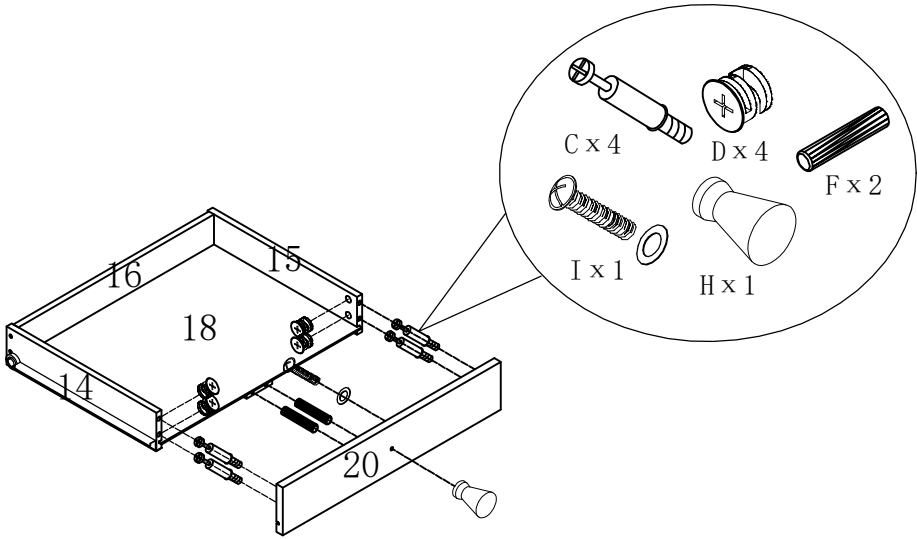

STEP4

STEP5

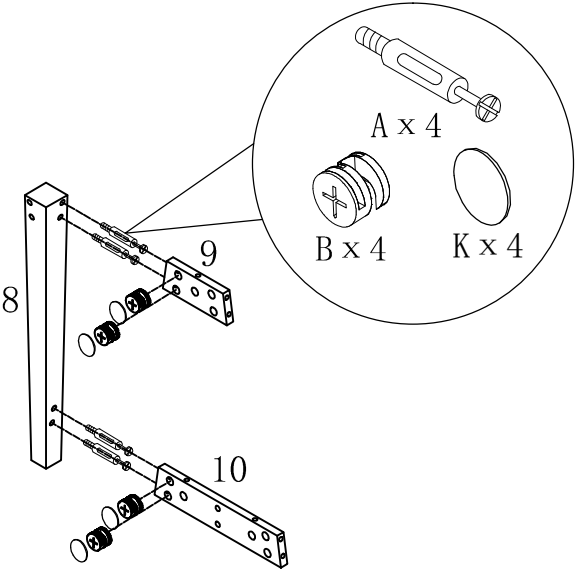

ASSEMBLY INSTRUCTION

ITEM#: 161620 M202756

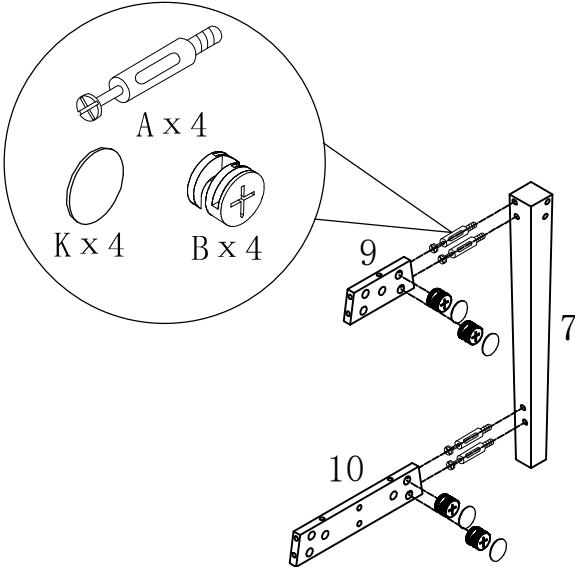

STEP6

STEP7

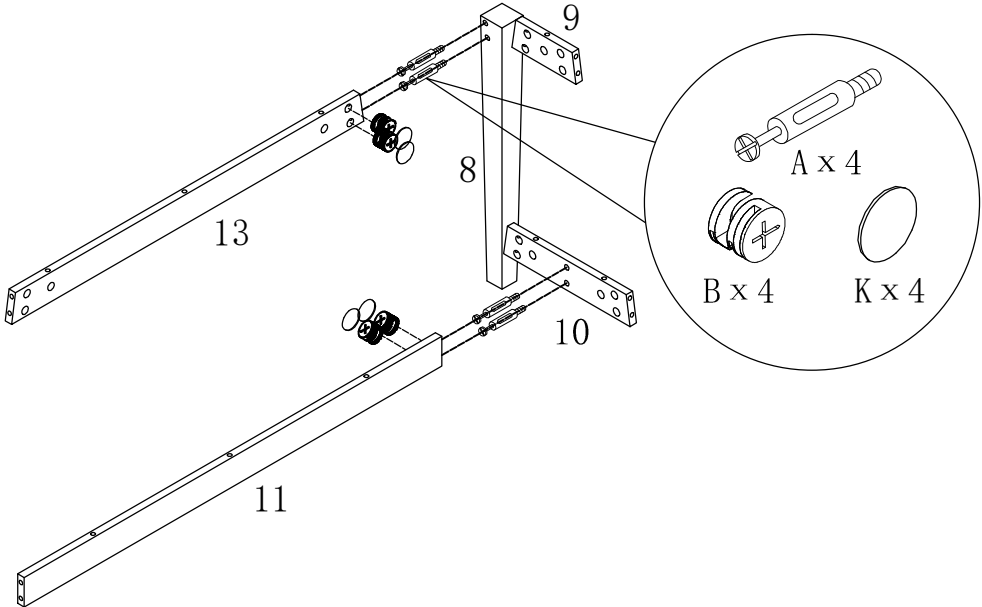

ASSEMBLY INSTRUCTION

ITEM#: 161620 M202756

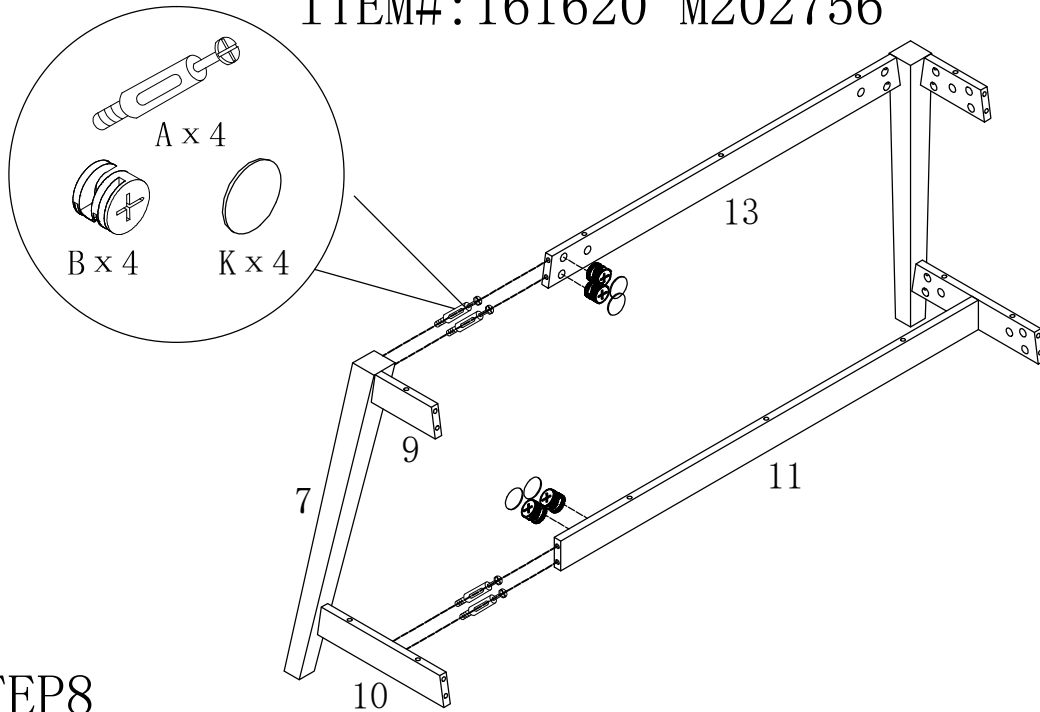

STEP8

STEP9

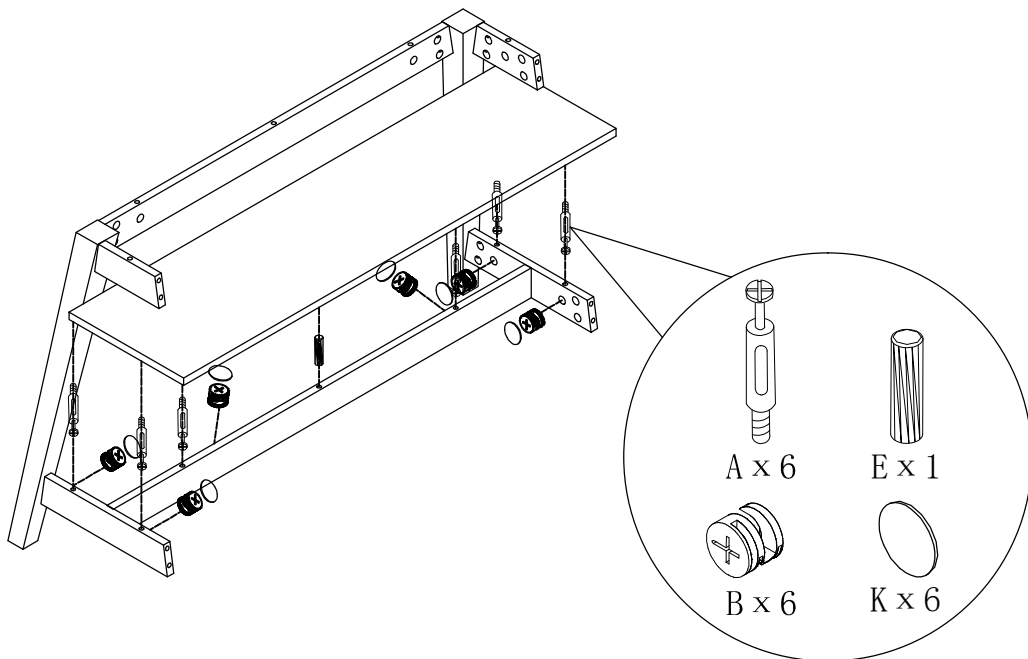

ASSEMBLY INSTRUCTION

ITEM#: 161620 M202756

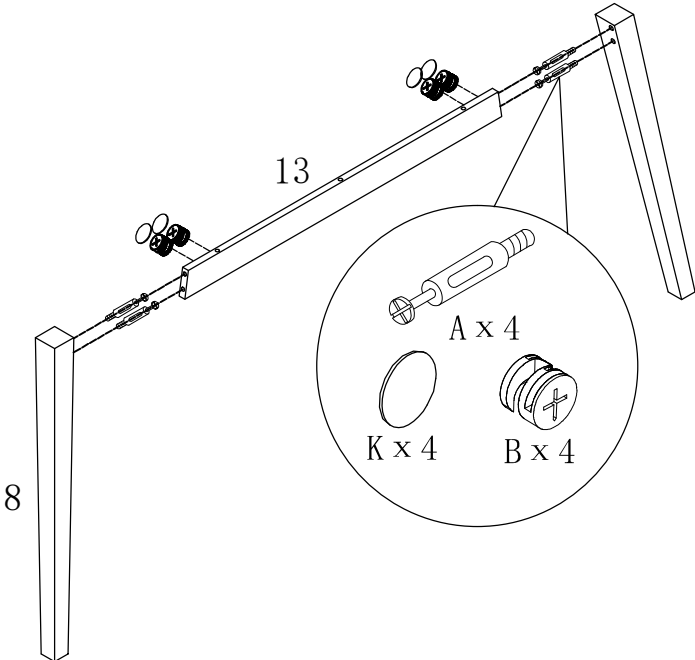

STEP10

STEP11

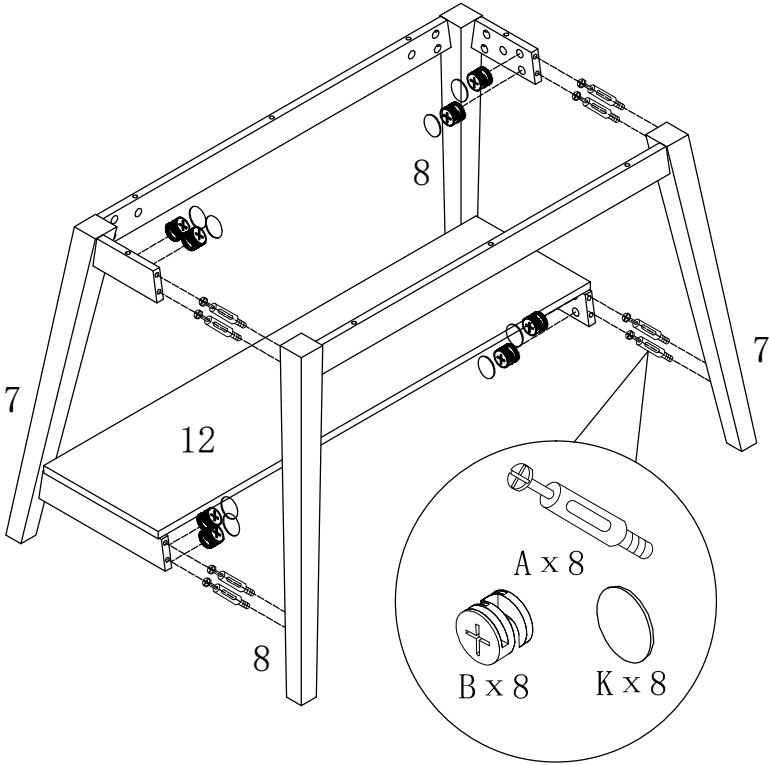

ASSEMBLY INSTRUCTION

ITEM#: 161620 M202756

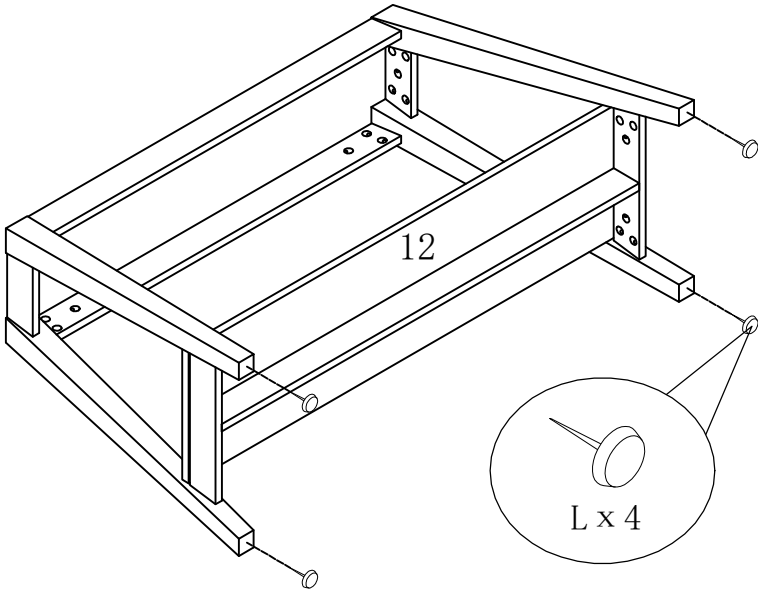

STEP12

STEP13

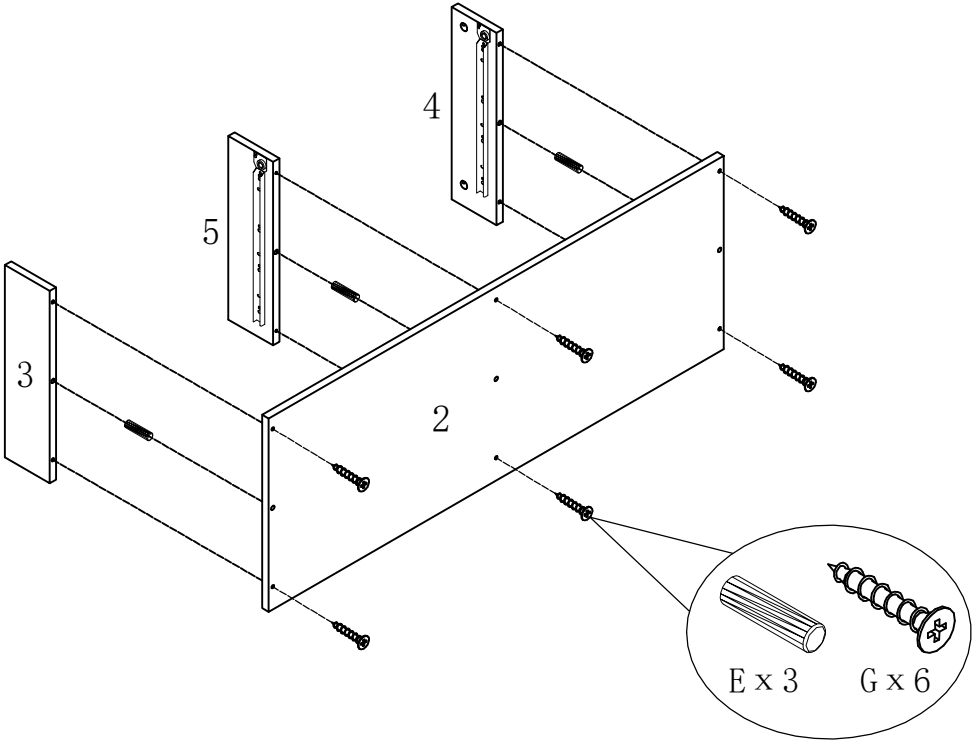

ASSEMBLY INSTRUCTION

ITEM#: 161620 M202756

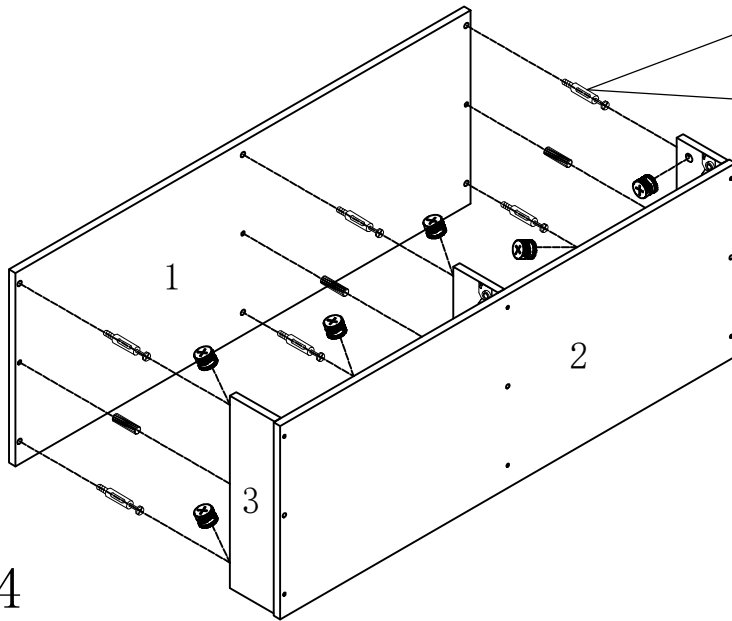

STEP14

STEP15

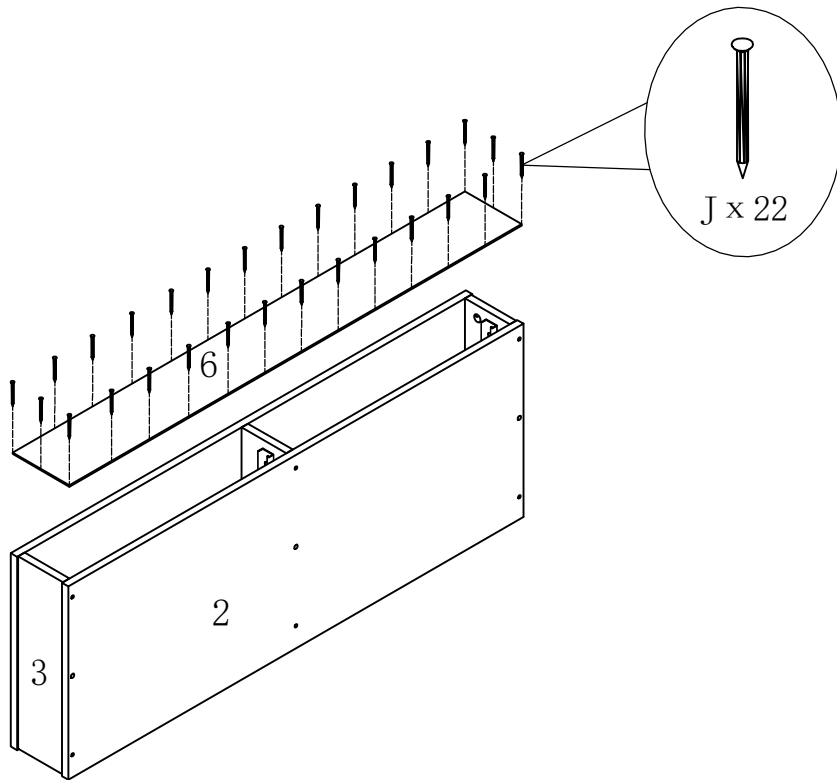

PAGE 11 OF 13

ASSEMBLY INSTRUCTION

ITEM#: 161620 M202756

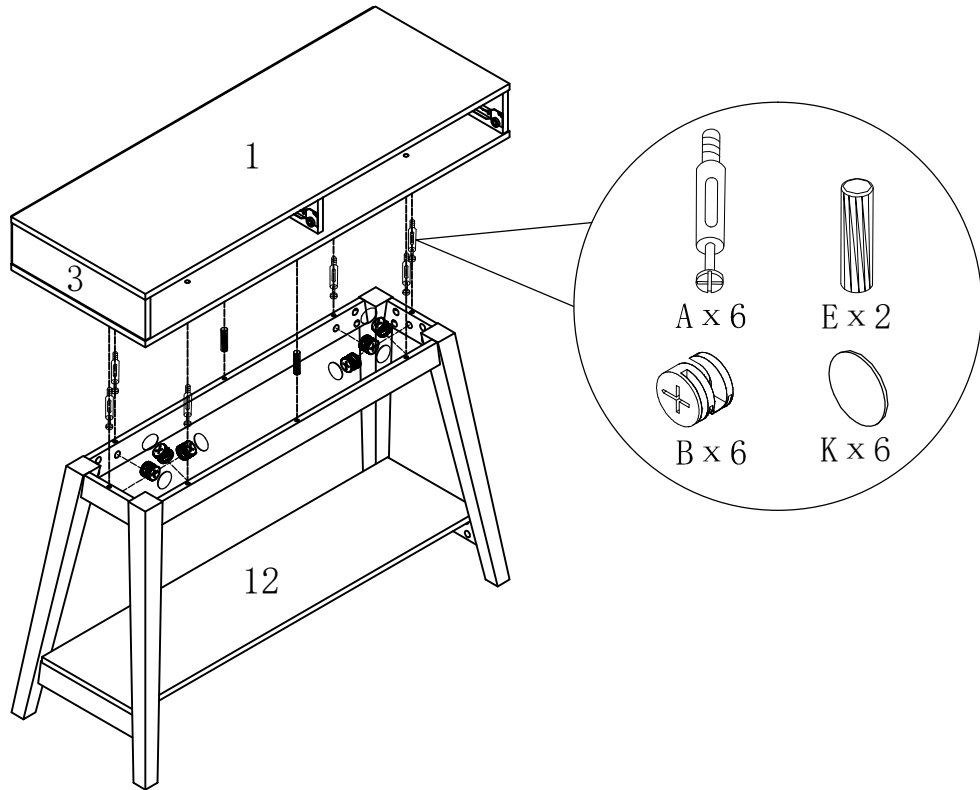

STEP16

STEP17

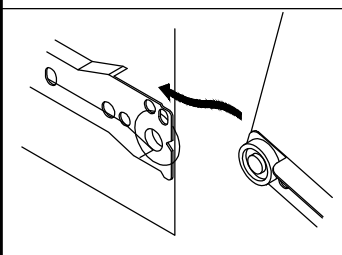
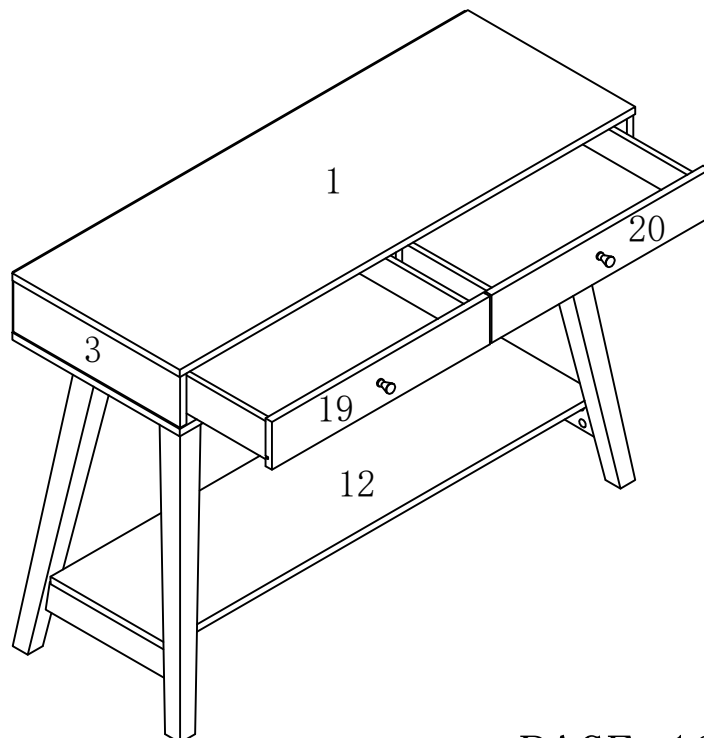

ANTI-TIPPING STRAP INSTRUCTION

HARDWARE (INCLUDED) :

TOOLS NEEDED (NOT INCLUDED) :

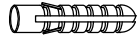

DRYWALL ANCHOR $\phi 8 \times 40$ X 1PC

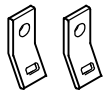

METAL BRACKETS $12 \times 12 \times 1$ X 2PCS

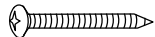

DRYWALL SCREW $\phi 5 \times 40$ X 1PC



STRAP $197 \times 5 \times 1$ X 1PC



FLATHEAD SCREW $\phi 4 \times 25$ X 1PC

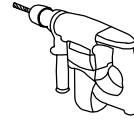

DRILL & DRILL BIT



LIGHT HAMMER

Note: Hardware included only compatible with standard drywalls.

STEP 1

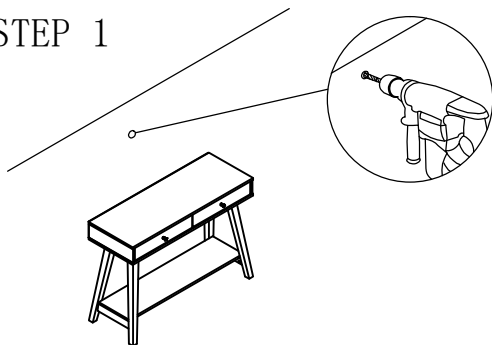

1. Find spot on wall 1" below top of item.
2. Using a drill bit slightly thinner than anchor, drill hole into drywall.

STEP 2

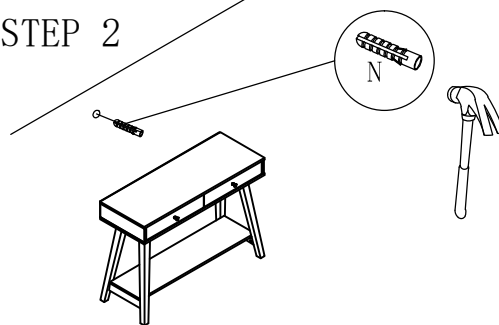

1. Use a light hammer to tap anchor into hole.
2. Anchor should fit snugly. If hole is too small, drill again to increase hole size. Do not force anchor into wall.

STEP 3

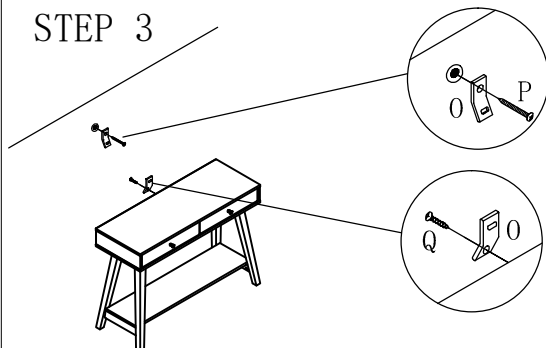

1. Insert drywall screw into metal bracket and into drywall anchor.
2. Insert flathead screw into second metal bracket and into back of item, along top edge.

STEP 4

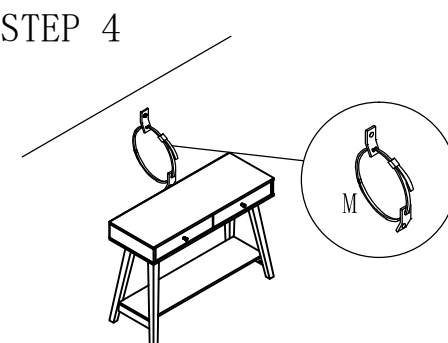

1. Insert strap thru bracket attached to wall, then thru bracket on item, and into head of strap.
 2. pull lightly til strap stops.
- Assembly is complete.