











# IFU 7020 BUNK BED ASSEMBLY INSTRUCTION

## HARDWARES LIST

You can use letters or numbers here.

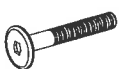
<p><b>A</b> </p> <p>(A) M6 X 90MM JCBC SCREW ( upper headboard - 8 pcs,side rail - 16 pcs, lower headboard - 8 pcs, long fencing - 4 pcs,short fencing - 2 pcs )</p>	<p>QTY</p> <p style="text-align: center;"><b>38</b></p>	<p><b>B</b> </p> <p>B) M6 X 20MM JCBC SCREW ( ladder hook )</p>	<p>QTY</p> <p style="text-align: center;"><b>4</b></p>	<p><b>C</b> </p> <p>C) M6 X 30MM JCBC SCREW ( fencing support )</p>	<p>QTY</p> <p style="text-align: center;"><b>12</b></p>
<p><b>D</b> </p> <p>D) M6 X 60MM JCBC SCREW ( ladder )</p>	<p style="text-align: center;"><b>8</b></p>	<p><b>E</b> </p> <p>E) M6 X 35MM JCBC SCREW ( center support legs )</p>	<p style="text-align: center;"><b>6</b></p>	<p><b>F</b> </p> <p>F) BARREL NUT M6 X 15MM ( lower headboard - 8 pcs,side rail - 16, upper headboard - 8 pcs,ladder - 8 pcs, long fencing - 4 pcs, short fencing - 2 pcs )</p>	<p style="text-align: center;"><b>46</b></p>
<p><b>G</b> </p> <p>G) M4 X 32MM CSK SCREW ( upper bunk - 12 pcs, lower bunk - 24 pcs)</p>	<p style="text-align: center;"><b>36</b></p>	<p><b>H</b> </p> <p>H) METAL PIN</p>	<p style="text-align: center;"><b>4</b></p>	<p><b>I</b> </p> <p>I) WOOD DOWEL M10 X 40MM ( lower headboard - 12 pcs, side rail - 8 pcs, upper headboard - 16 pcs, long fencing - 4 pcs,short fencing - 2 pcs )</p>	<p style="text-align: center;"><b>42</b></p>
<p><b>J</b> </p> <p>(J) M6 X 40MM JCBC SCREW ( ladder )</p>	<p style="text-align: center;"><b>4</b></p>	<p><b>K</b> </p> <p>(K) M4 ALLEN KEY ( ball type )</p>	<p style="text-align: center;"><b>2</b></p>	<p><b>L</b> </p> <p>(L) LADDER HOOK</p>	<p style="text-align: center;"><b>2</b></p>

















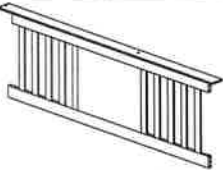

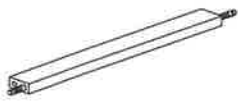
### Important

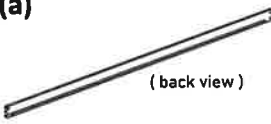
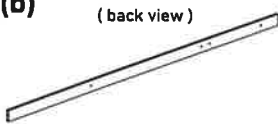
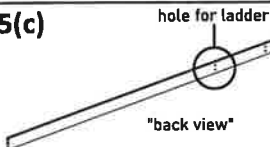
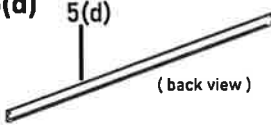
1. Before you throw the package , please use the Check Box to identify the parts and hardware to ensure that you have everything you need.
2. Check and measure the bolts before applying them to parts.
3. Do not completely tighten all hardware until the entire assembly is complete, unless indicate otherwise.

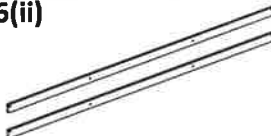
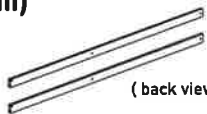
# IFU 7020 BUNK BED ASSEMBLY INSTRUCTION

## PARTS LIST

<b>1(i)</b>  1(i) (no hole for fencing) (1 pc) UPPER BUNK POST 1(i) - ( no hole for fencing )	<b>QTY</b>  <b>1</b>	<b>1(ii)</b>  1(ii) (3 pcs) (hole for fencing) UPPER BUNK POST 1(ii) - ( hole for fencing )	<b>QTY</b>  <b>2</b>	<b>1(iii)</b>  UPPER BUNK POST 1(iii) - ( hole for fencing )	<b>QTY</b>  <b>1</b>
<b>2(i)</b>  LOWER BUNK POST 2(i)	<b>QTY</b>  <b>2</b>	<b>2(ii)</b>  LOWER BUNK POST 2(ii)	<b>QTY</b>  <b>2</b>	<b>3(i)</b>  UPPER BUNK HEADBOARD	<b>2</b>
<b>3(ii)</b>  LOWER BUNK HEADBOARD	<b>2</b>	<b>4(i)</b>  LONG LADDER POST ( LEFT )	<b>1</b>	<b>4(ii)</b>  LADDER STEP	<b>4</b>
<b>4(iii)</b>  SHORT LADDER POST ( RIGHT )	<b>1</b>	<b>5(a)</b>  ( back view ) UPPER BUNK SIDE RAIL ( LEFT )	<b>1</b>	<b>5(b)</b> ( back view )  UPPER BUNK SIDE RAIL ( RIGHT )	<b>1</b>
<b>5(c)</b> hole for ladder  "back view" LOWER BUNK SIDE RAIL ( RIGHT )	<b>1</b>	<b>5(d)</b> 5(d)  ( back view ) LOWER BUNK SIDE RAIL ( LEFT )	<b>1</b>	<b>6(i)</b>  ( back view ) FENCING SUPPORT	<b>4</b>
<b>6(ii)</b>  LONG GUARDRAILS	<b>1</b>	<b>6(iii)</b>  ( back view ) SHORT GUARDRAILS	<b>1</b>	<b>7</b>  TOP WOODEN SLAT ( 14 SLAT )	<b>1</b>
<b>8</b>  BOTTOM WOODEN SLAT ( 12 SLAT )	<b>1</b>	<b>8</b>  CENTER RAIL	<b>3</b>	<b>8</b>  CENTER SUPPORT LEGS	<b>6</b>



### Important

1. Before you throw the package , please use the Check Box to identify the parts and hardware to ensure that you have everything you need.
2. Check and measure the bolts before applying them to parts.
3. Do not completely tighten all hardware until the entire assembly is complete, unless indicate otherwise.

# IFU 7020 BUNK BED ASSEMBLY INSTRUCTION

## Step 1 LOWER BUNK POST AND HEADBOARD ASSEMBLY

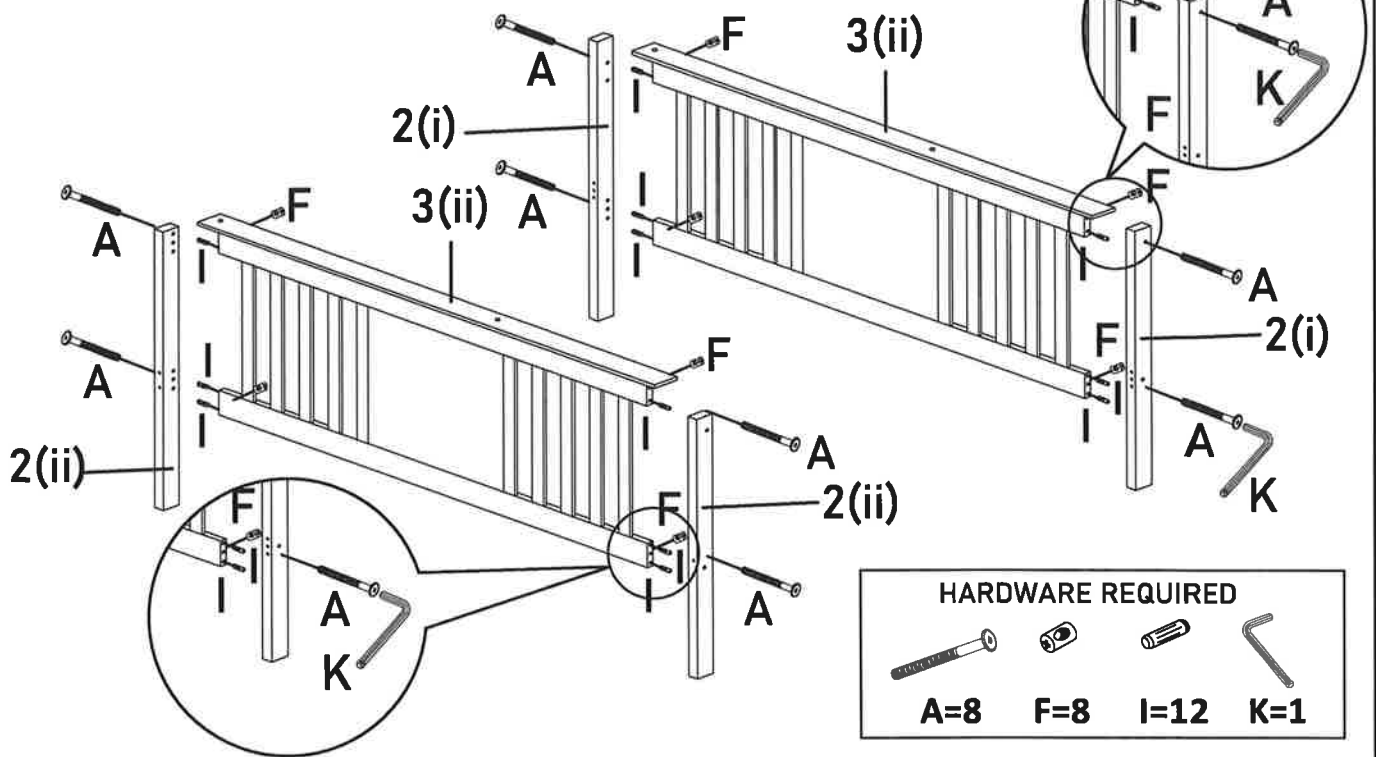

## Step 2 LOWER BUNK HEADBOARD AND SIDE RAIL ASSEMBLY

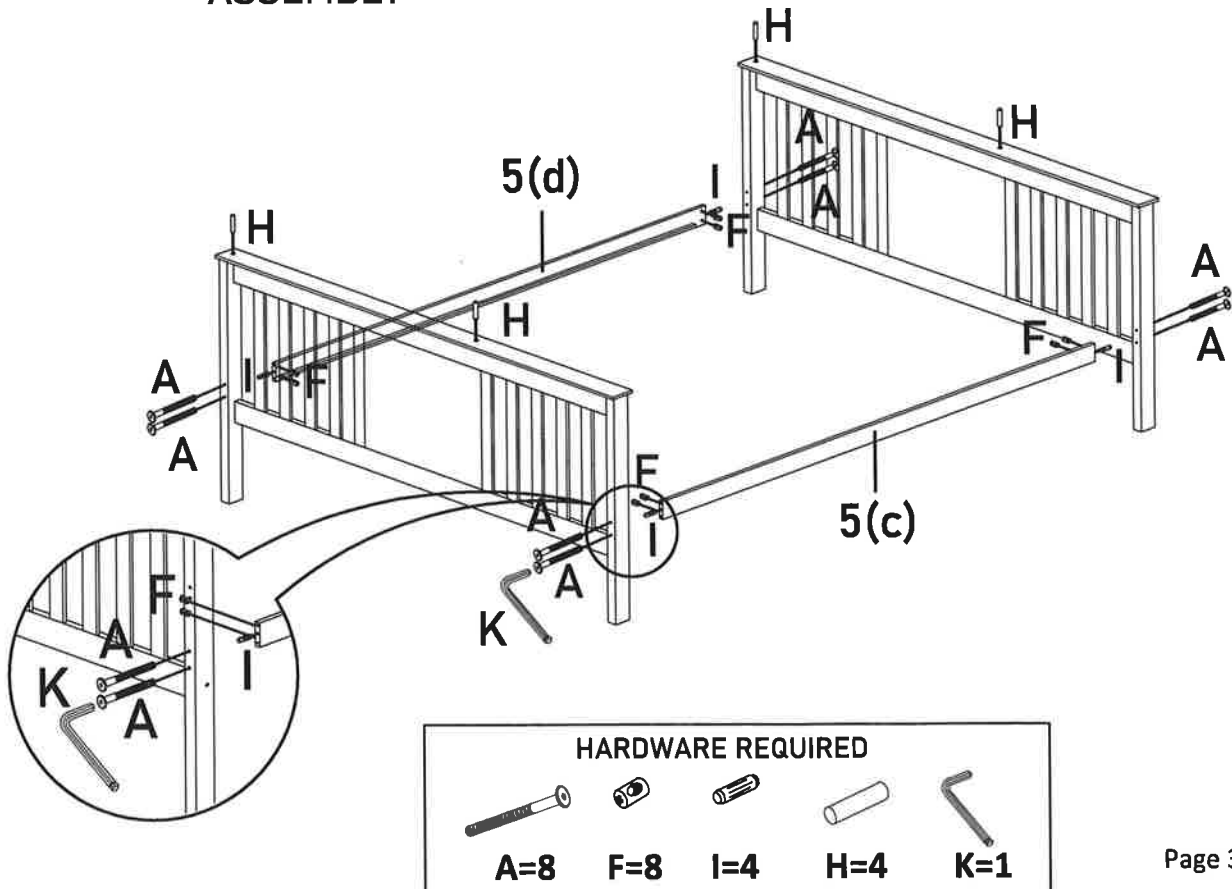

# IFU 7020 BUNK BED ASSEMBLY INSTRUCTION

## Step 3 UPPER BUNK POST AND HEADBOARD ASSEMBLY

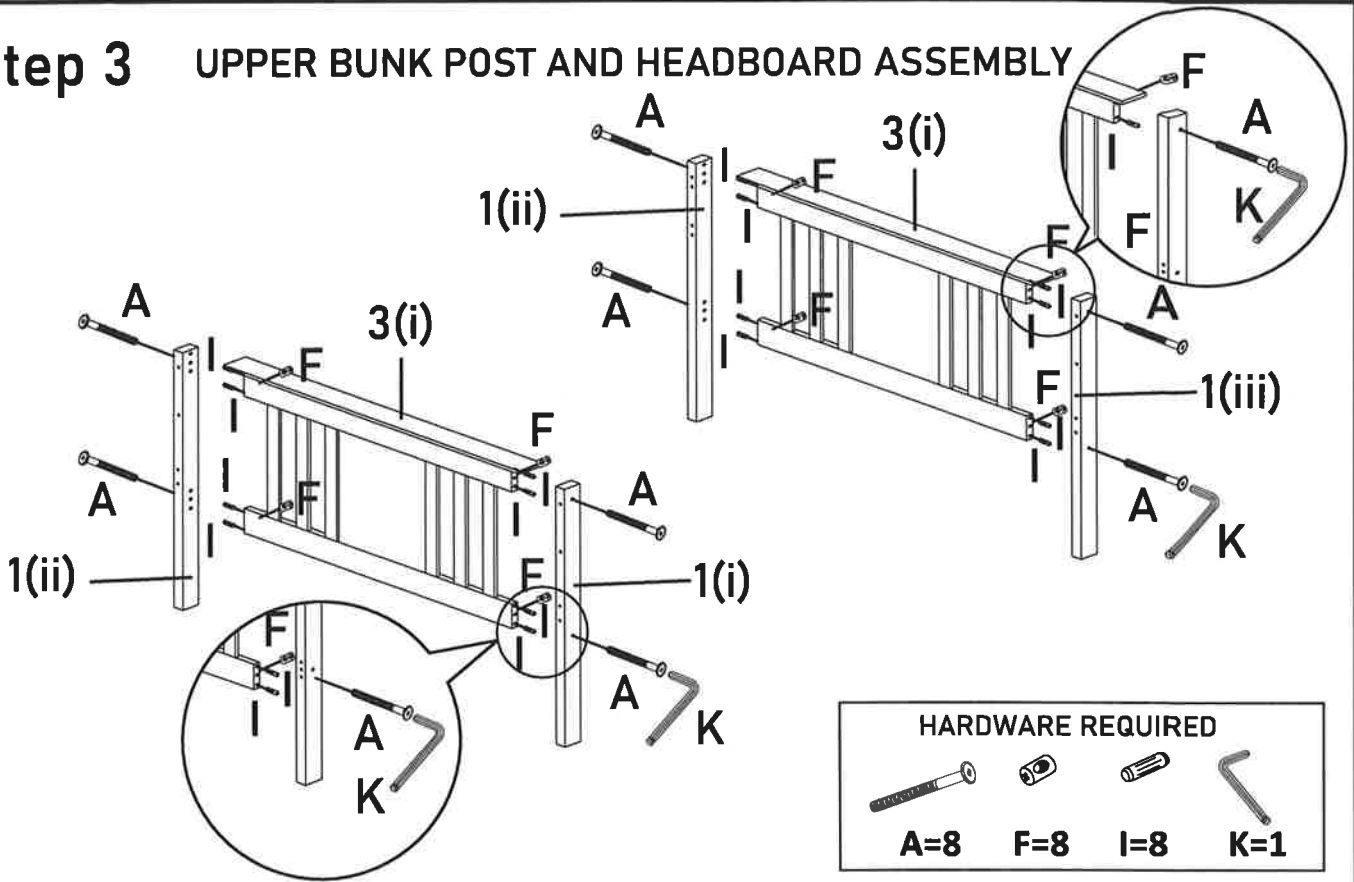

## Step 4 LONG GUARDRAIL ASSEMBLY

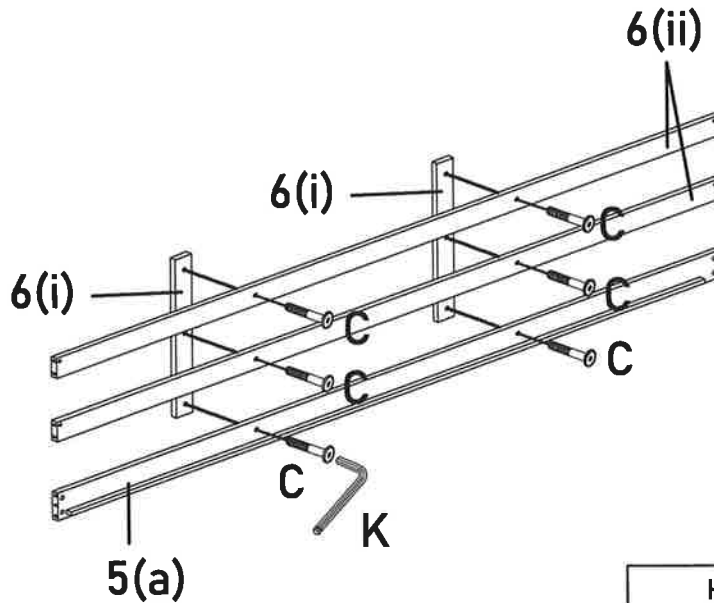

# IFU 7020 BUNK BED ASSEMBLY INSTRUCTION

## Step 5 UPPER BUNK HEADBOARD AND SIDE RAIL ASSEMBLY

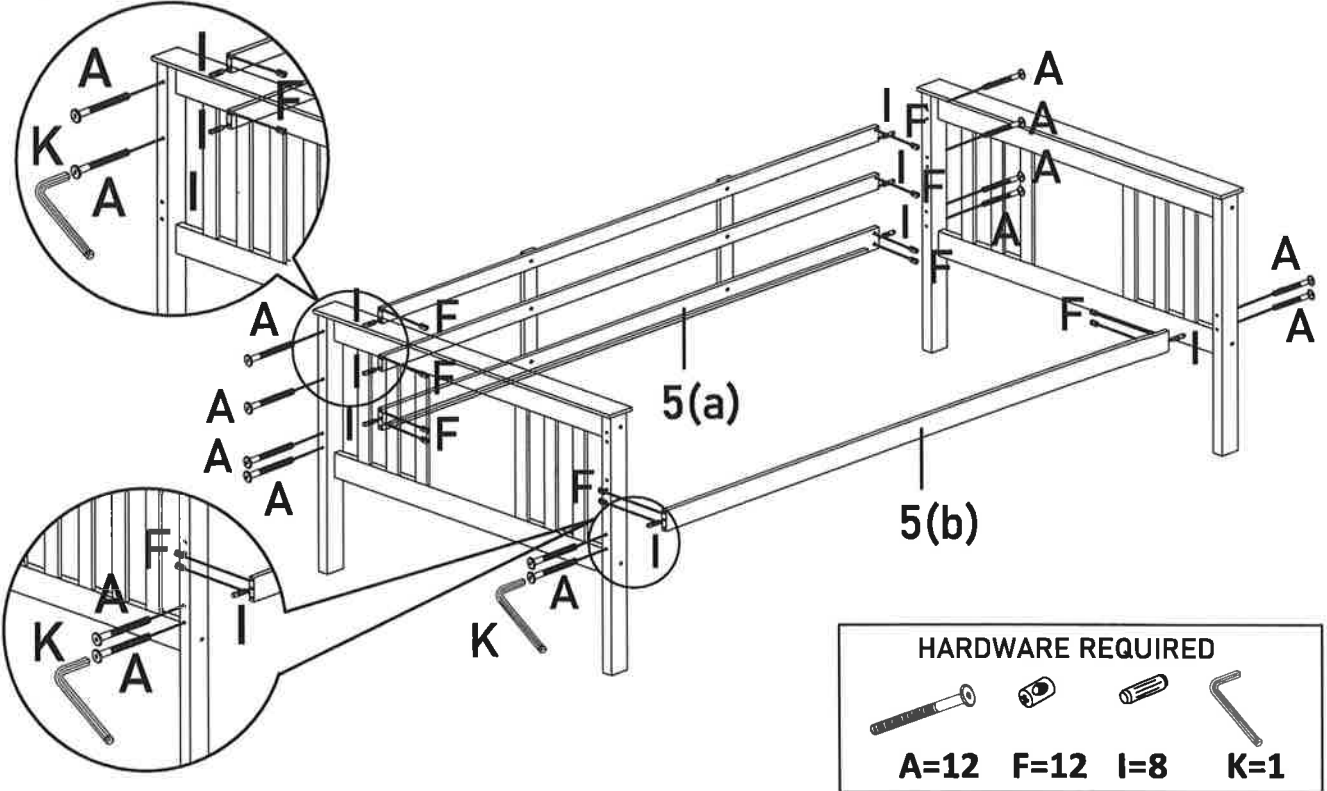

## Step 6 CARRY UPPER BUNK TO PLACE ON LOWER BUNK ASSEMBLY

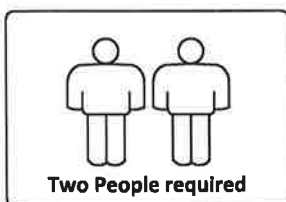
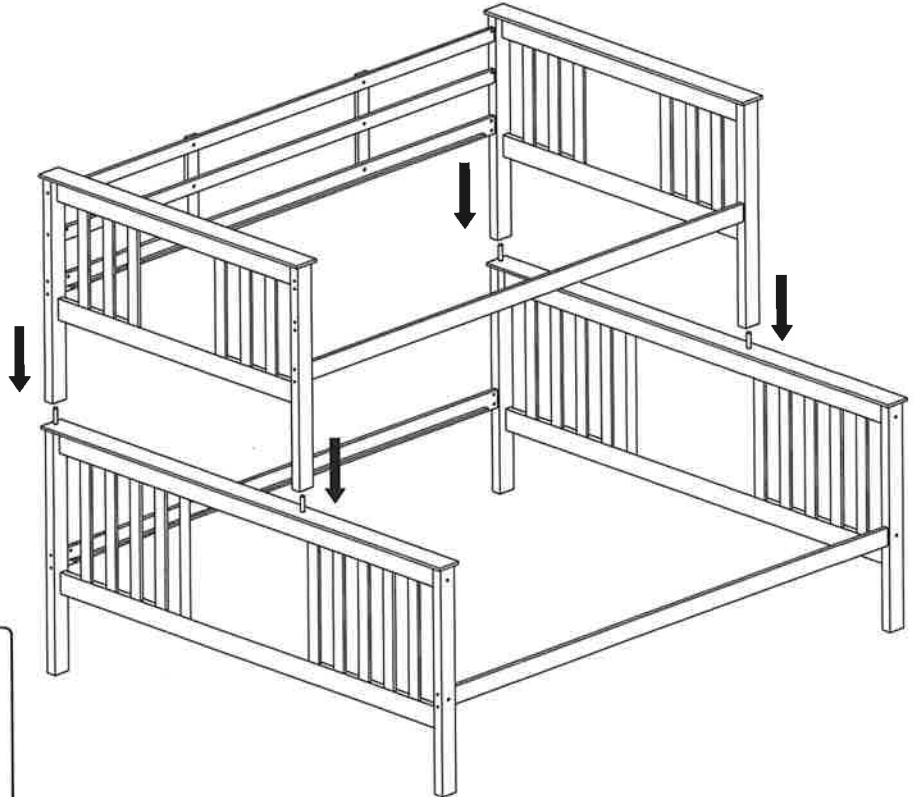



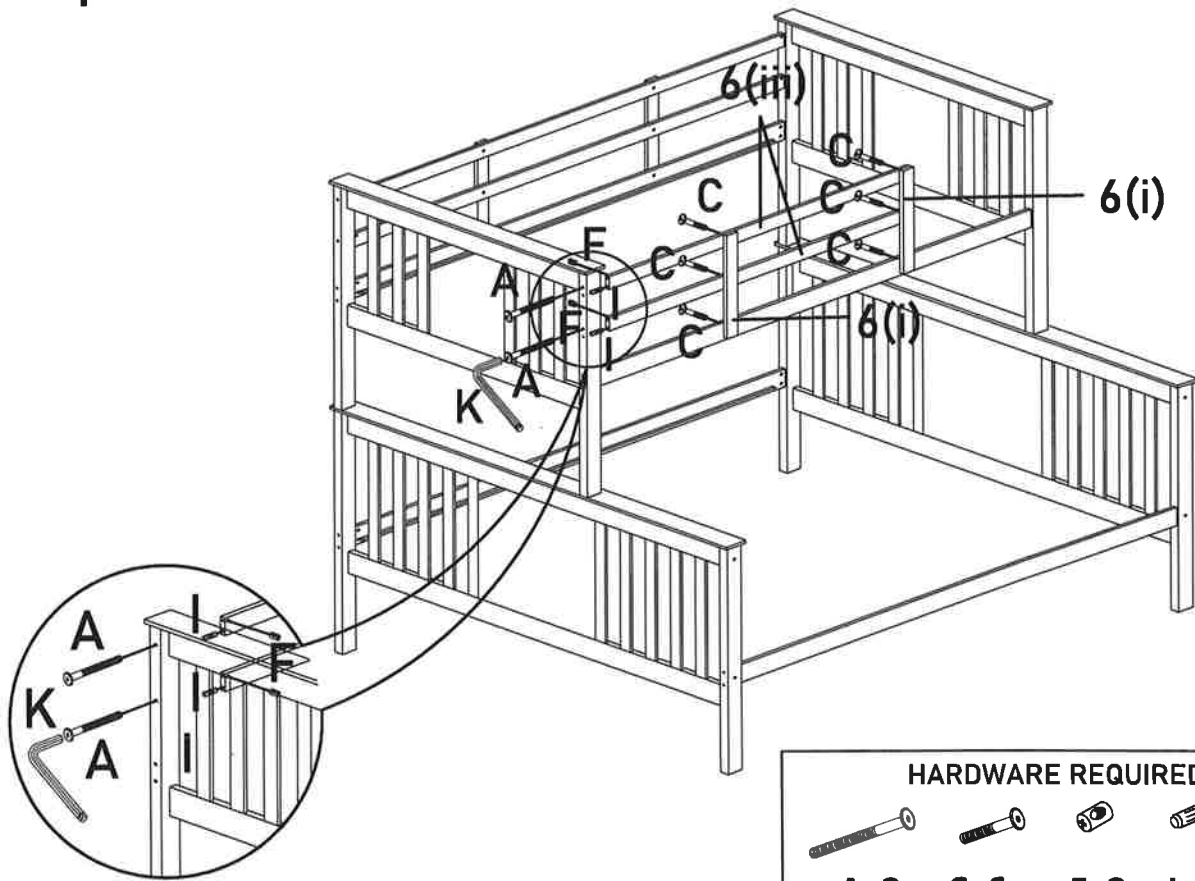

# IFU 7020 BUNK BED ASSEMBLY INSTRUCTION

## Step 7 SHORT GUARDRAIL ASSEMBLY





**HARDWARE REQUIRED**

				
<b>A=2</b>	<b>C=6</b>	<b>F=2</b>	<b>I=2</b>	<b>K=1</b>

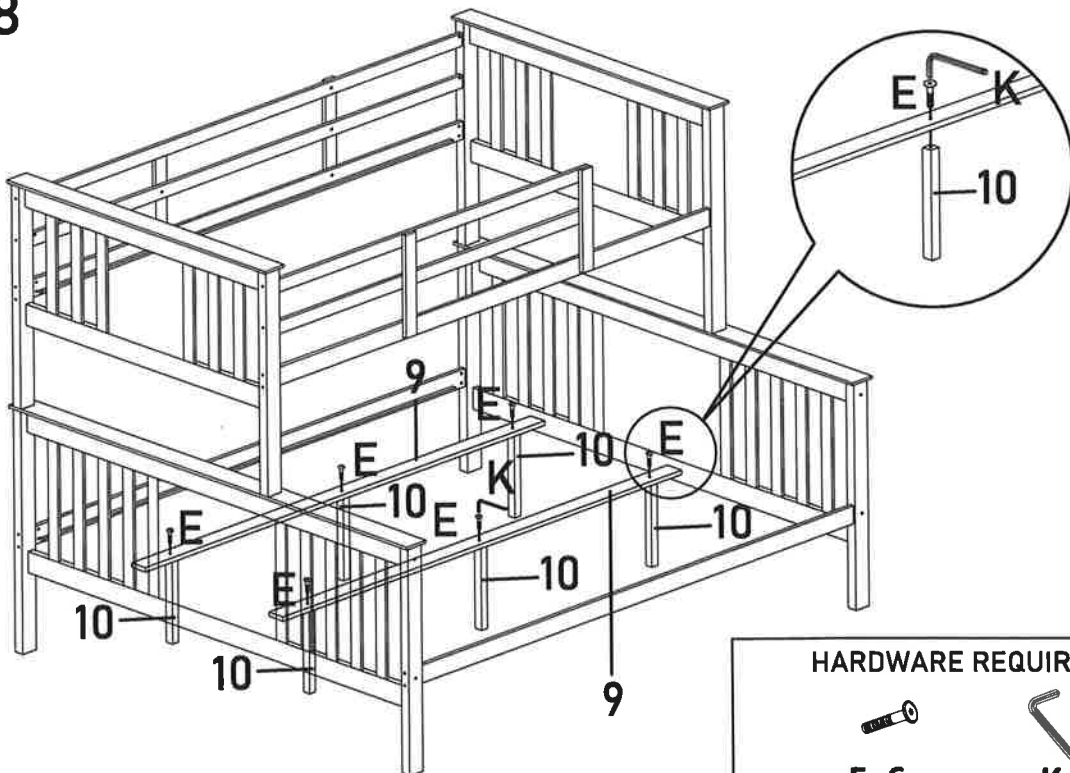
## Step 8



**HARDWARE REQUIRED**

	
<b>E=6</b>	<b>K=1</b>

# IFU 7020 BUNK BED ASSEMBLY INSTRUCTION

## Step 9

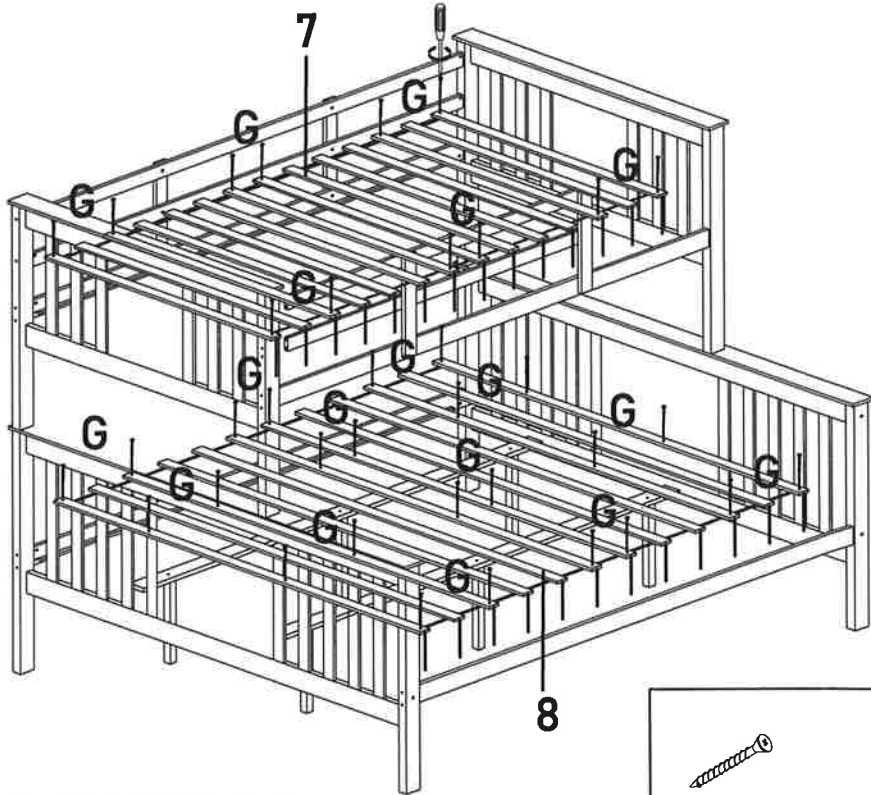

WOODEN SLAT ASSEMBLY

**REQUIRED ASSEMBLY TOOLS:**  
POZI SCREWDRIVER - IPC

**G=36** upper bunk - 12 pcs  
lower bunk - 24 pcs

## Step 10

LADDER ASSEMBLY

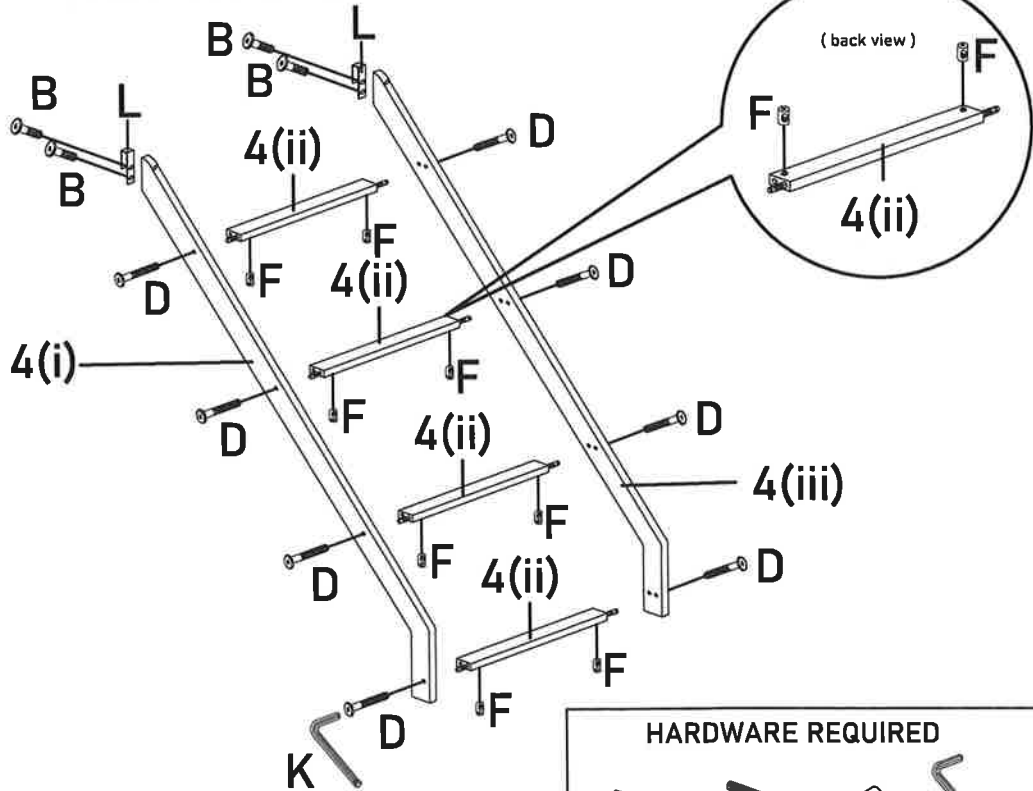

**HARDWARE REQUIRED**

**B=4** **D=8** **F=8** **K=1**

# IFU 7020 BUNK BED ASSEMBLY INSTRUCTION

## Step 11

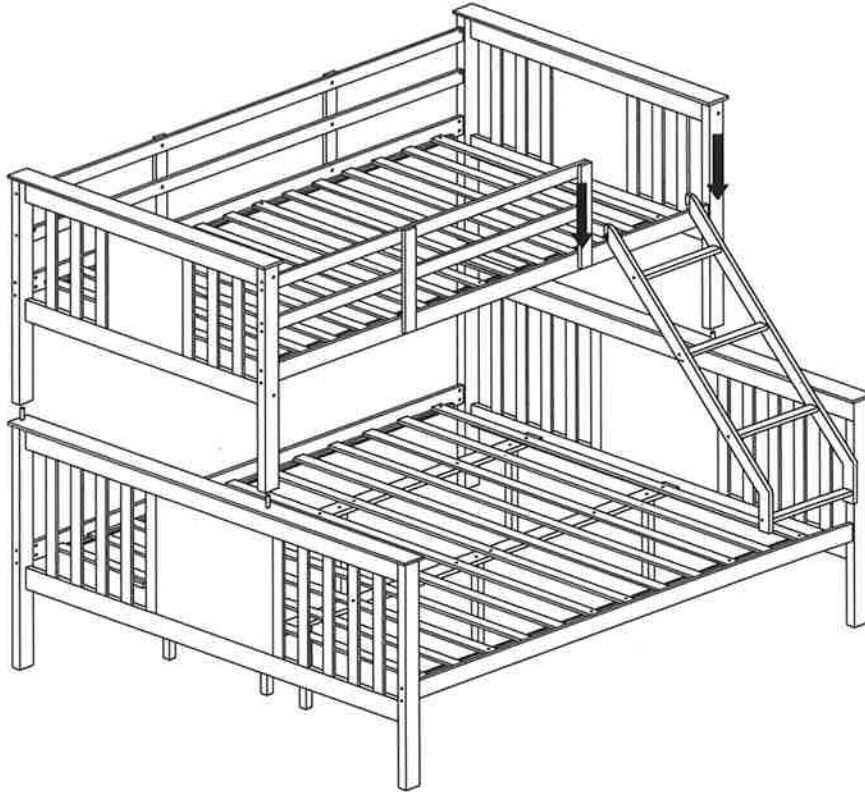

CARRY LADDER TO PLACE ON UPPER BUNK ASSEMBLY

## Step 12

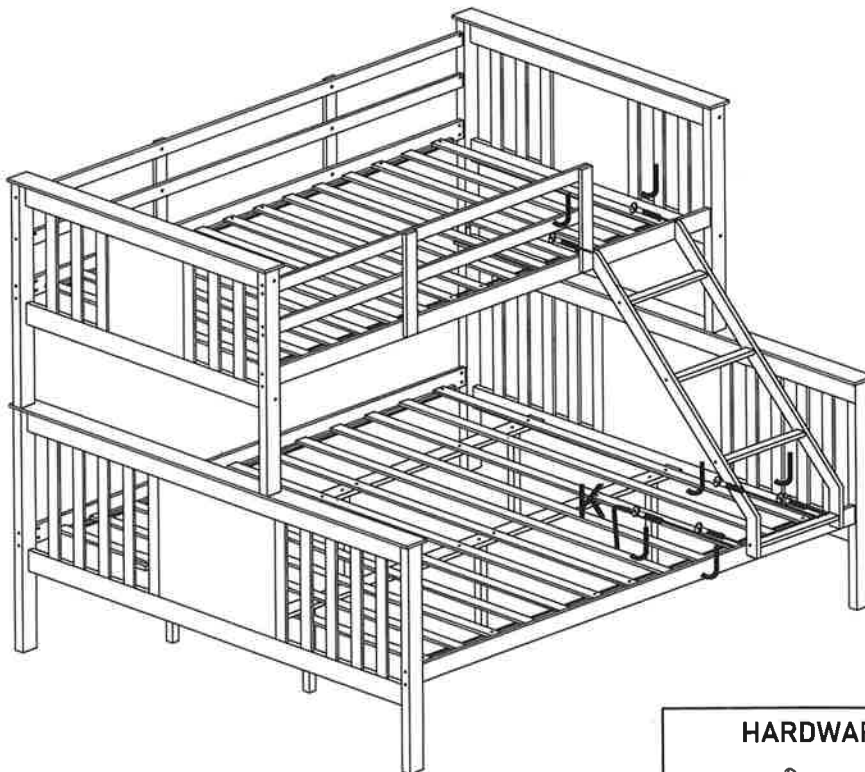

LADDER ASSEMBLY

HARDWARE REQUIRED



J=4



K=1



# IFU 7020 BUNK BED ASSEMBLY INSTRUCTION

" FULL SETUP "

