

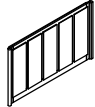

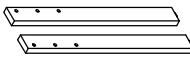

ASSEMBLY INSTRUCTIONS

ITEM NO = C0367A-QP0
DESCRIPTION = QUEEN PANEL HEADBOARD

Place all wood parts on a clean and smooth surface to keep them from being scratched.

ITEM	DRAWING	DESCRIPTION	QTY
A		HEADBOARD	1
B		HB - LEG L / R	2

ITEM	DRAWING	DESCRIPTION	QTY
1		JCBB (M8 x 35mm)	6
2		SPRING WASHER (M8)	6
3		FLAT WASHER (M8 x 18)	6
4		ALLEN KEY (M5)	1

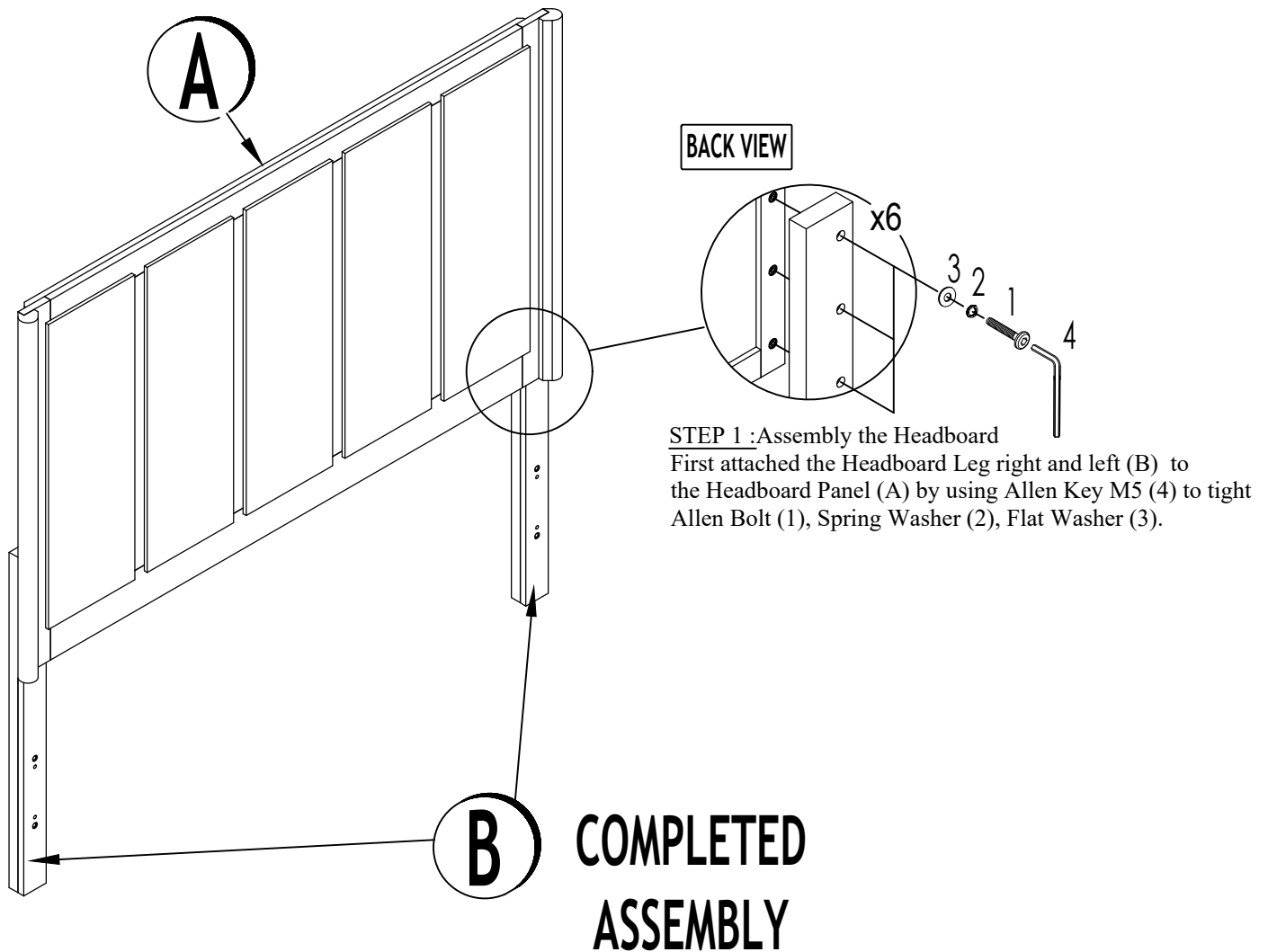

NOTE: SCREWS LOOSEN WITH USE.
CHECK FOR LOOSE SCREWS AND TIGHTEN EVERY 6-8 WEEKS

CLEANING INSTRUCTIONS:

If necessary, clean & polish all surfaces after assembly with a soft cloth and industrial furniture polish.

MADE IN MALAYSIA

ASSEMBLY INSTRUCTIONS

ITEM NO = C0367A-Q3S / C0367A-BTN / C0367A-QXJ
 DESCRIPTION = QUEEN STORAGE FOOTBOARD
 W/12 SLATS, 7 SUPPORTS /
 QUEEN / KING STORAGE SIDE RAIL SET (2) /
 QUEEN FOOTBOARD DRAWER CASE SET (2), 2 DRAWERS

Place all wood parts on a clean and smooth surface to keep them from being scratched.

ITEM	DRAWING	DESCRIPTION	QTY
A		HEADBOARD	1
B		FOOTBOARD	1
C		SIDE RAIL LEFT & RIGHT	2
D		SLAT	1 SET
E		CENTER SLAT	1
F		DRAWER BOX	2
G		FOOTBOARD DRAWER SUPPORT	2
H		VERTICAL LEG (334mm)	4
I		VERTICAL LEG (193mm)	1
J		VERTICAL LEG (110mm)	2
K		DECKING BOARD	1
L		FOOTBOARD SUPPORT	1

ITEM	DRAWING	DESCRIPTION	QTY
1		JCBC M6 x 35mm	12
2		SPRING WASHER (M6)	12
3		FLAT WASHER (M6 x 13)	12
4		WOOD DOWEL (Ø8 x 30)	8
5		PANHEAD SCREW (M4 x 30mm)	29
6		ALLEN KEY (M4)	1
7		PANHEAD SCREW (M4 x 12mm)	4

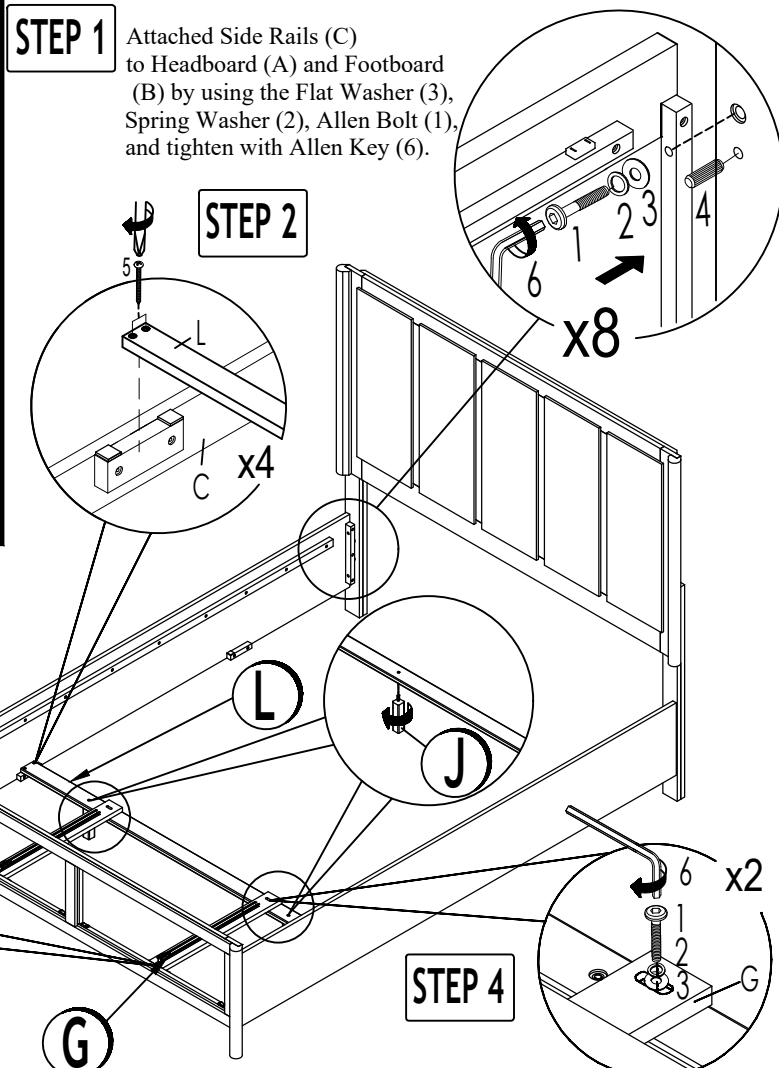

CLEANING INSTRUCTIONS:

If necessary, clean & polish all surfaces after assembly with a soft cloth and industrial furniture polish.

MADE IN MALAYSIA

ASSEMBLY INSTRUCTIONS

ITEM NO = C0367A-Q3S / C0367A-BTN / C0367A-QXJ

DESCRIPTION = QUEEN STORAGE FOOTBOARD

W/12 SLATS, 7 SUPPORTS /

QUEEN / KING STORAGE SIDE RAIL SET (2) /

QUEEN FOOTBOARD DRAWER CASE SET (2), 2 DRAWERS

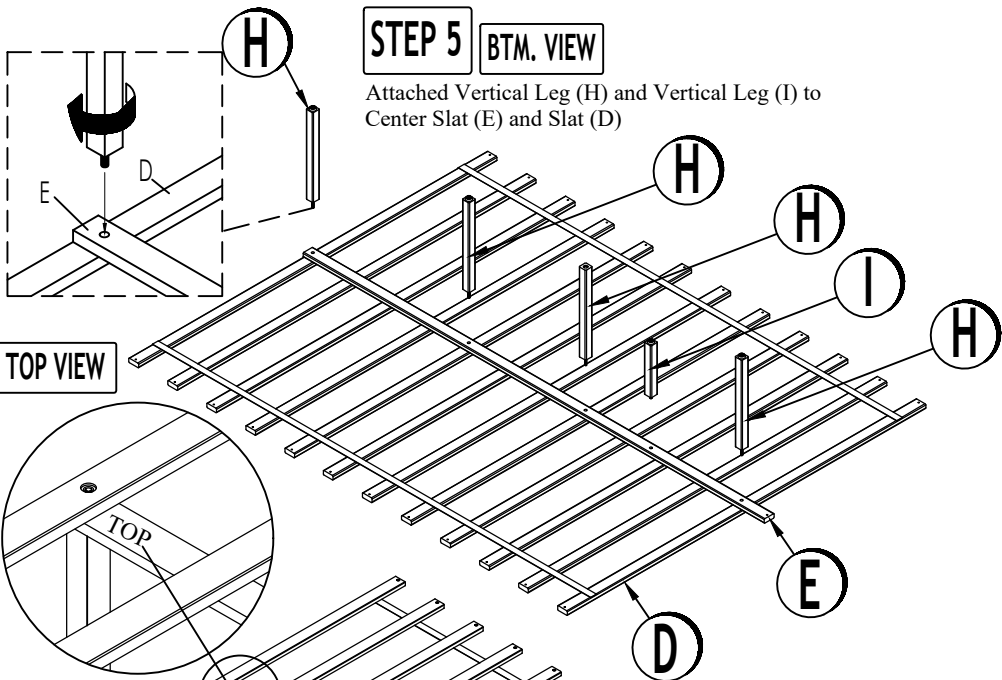

STEP 5 BTM. VIEW

Attached Vertical Leg (H) and Vertical Leg (I) to Center Slat (E) and Slat (D)

STEP 6

Attached Slat (D) to Side Rail (C) with Panhead Screw (5), and tighten with Screw Driver.

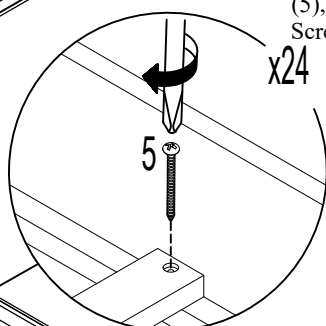

x24

5

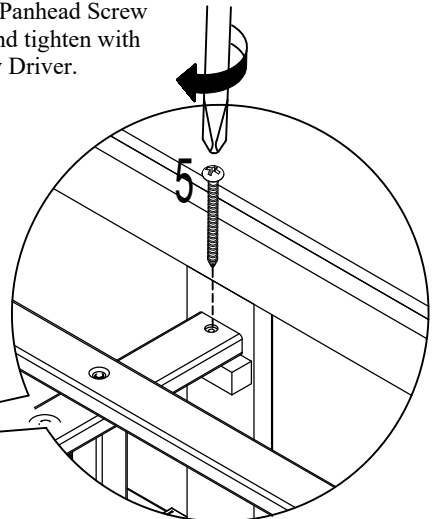

STEP 7

TOP VIEW

Attached Center Slat (E) to wood holder by using the Panhead Screw (5) and tighten with screw driver.

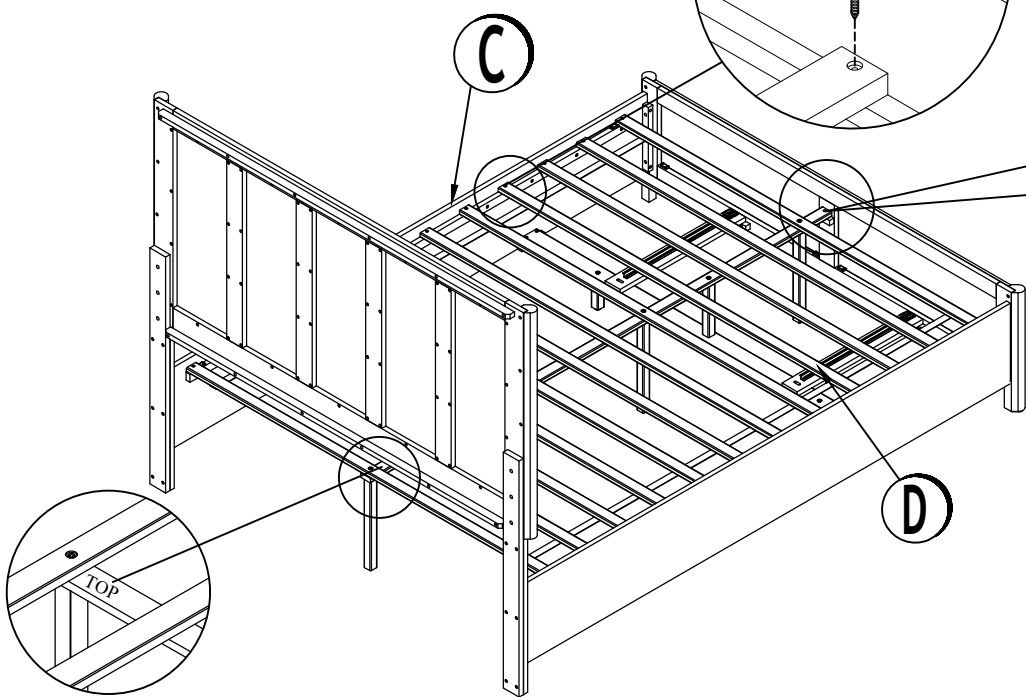

NOTE: SCREWS LOOSEN WITH USE.
CHECK FOR LOOSE SCREWS AND TIGHTEN EVERY 6-8 WEEKS

CLEANING INSTRUCTIONS:

If necessary, clean & polish all surfaces after assembly with a soft cloth and industrial furniture polish.

MADE IN MALAYSIA

ASSEMBLY INSTRUCTIONS

ITEM NO = C0367A-Q3S / C0367A-BTN / C0367A-QXJ
DESCRIPTION = QUEEN STORAGE FOOTBOARD
W/12 SLATS, 7 SUPPORTS /
QUEEN / KING STORAGE SIDE RAIL SET (2) /
QUEEN FOOTBOARD DRAWER CASE SET (2), 2 DRAWERS

STEP 9

Unscrewing the handle screw from outside, take out the handle from the drawer and install handle at drawer front

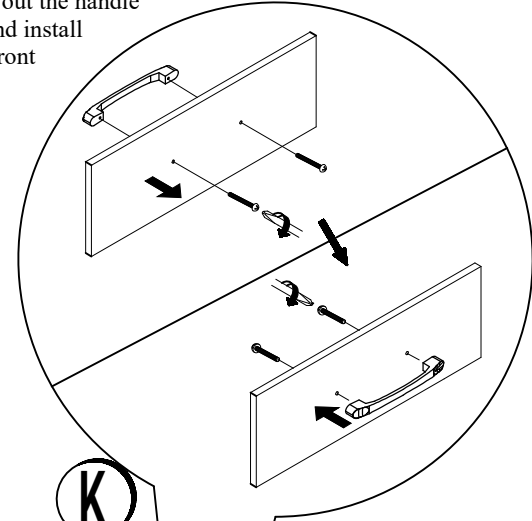

STEP 8

Attached Decking Board (K) to Slat (D), from below with Panhead Screw (7), and tighten with Screw Driver.

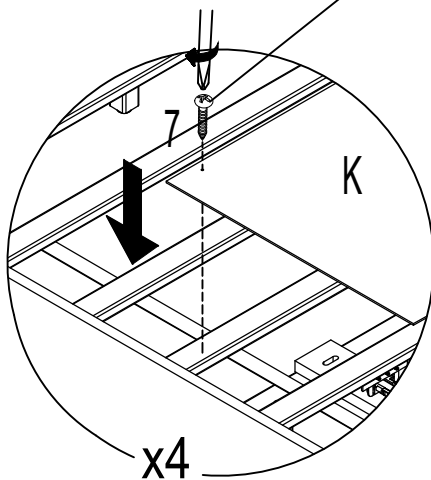

**COMPLETED
ASSEMBLY**

NOTE: SCREWS LOOSEN WITH USE.
CHECK FOR LOOSE SCREWS AND TIGHTEN EVERY 6-8 WEEKS

CLEANING INSTRUCTIONS:

If necessary, clean & polish all surfaces after assembly with a soft cloth and industrial furniture polish.

MADE IN MALAYSIA