

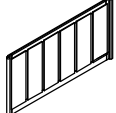

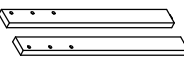

# ASSEMBLY INSTRUCTIONS

ITEM NO = C0367A-GP0  
DESCRIPTION = KING / CALIFORNIA KING PANEL  
HEADBOARD

Place all wood parts on a clean and smooth surface to keep them from being scratched.

ITEM	DRAWING	DESCRIPTION	QTY
A		HEADBOARD	1
B		HB - LEG L / R	2

ITEM	DRAWING	DESCRIPTION	QTY
1		JCBB (M8 x 35mm)	6
2		SPRING WASHER (M8)	6
3		FLAT WASHER (M8 x 18)	6
4		ALLEN KEY (M5)	1

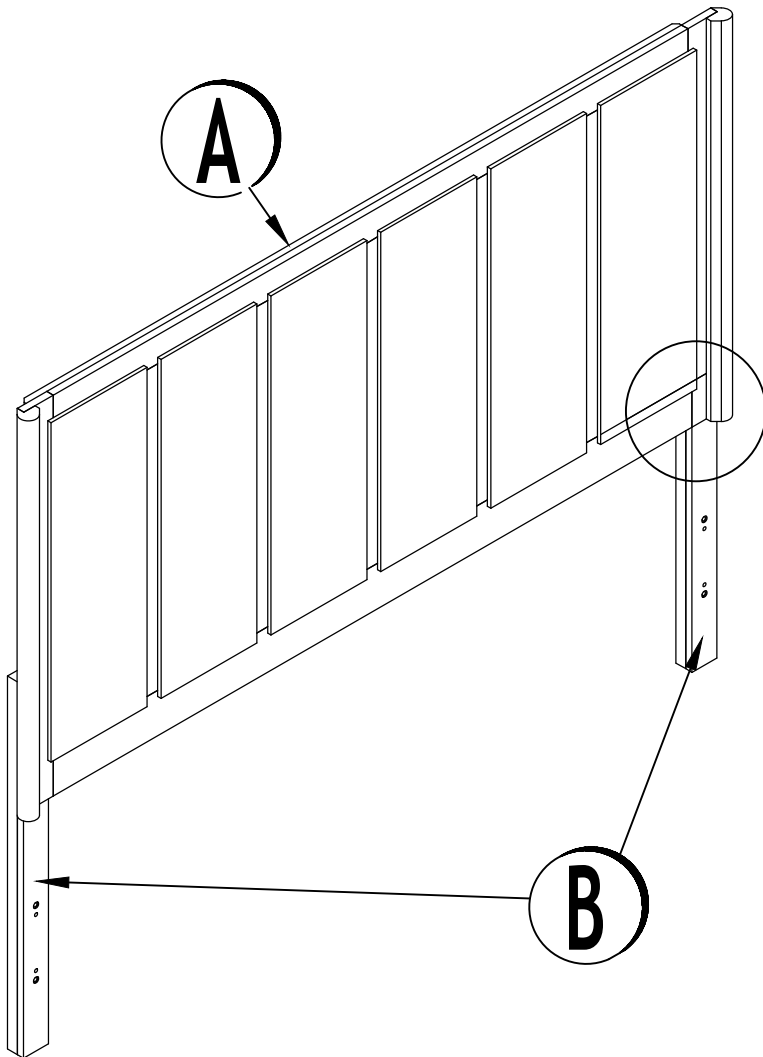

BACK VIEW

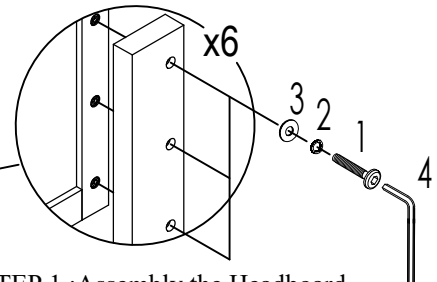

**STEP 1 : Assembly the Headboard**  
First attached the Headboard Leg right and left (B) to the Headboard Panel (A) by using Allen Key M5 (4) to tight Allen Bolt (1), Spring Washer (2), Flat Washer (3).

**COMPLETED  
ASSEMBLY**

NOTE: SCREWS LOOSEN WITH USE.  
CHECK FOR LOOSE SCREWS AND TIGHTEN EVERY 6-8 WEEKS

**CLEANING INSTRUCTIONS:**

If necessary, clean & polish all surfaces after assembly with a soft cloth and industrial furniture polish.

MADE IN MALAYSIA

# ASSEMBLY INSTRUCTIONS

ITEM NO = C0367A-G3S / C0367A-BTN / C0367A-GXJ  
 DESCRIPTION = KING/CAL.KING STORAGE FOOTBOARD W/12 SLATS, 7 SUPPORTS /  
 QUEEN / KING STORAGE SIDE RAIL SET (2) /  
 KING / CALIFORNIA KING FOOTBOARD DRAWER  
 CASE SET (2), 2 DRAWERS

Place all wood parts on a clean and smooth surface to keep them from being scratched.

ITEM	DRAWING	DESCRIPTION	QTY
A		HEADBOARD	1
B		FOOTBOARD	1
C		SIDE RAIL LEFT & RIGHT	2
D		SLAT	1 SET
E		CENTER SLAT	1
F		DRAWER BOX	2
G		FOOTBOARD DRAWER SUPPORT	2
H		VERTICAL LEG (334mm)	4
I		VERTICAL LEG (193mm)	1
J		VERTICAL LEG (110mm)	2
K		DECKING BOARD	1
L		FOOTBOARD SUPPORT	1

ITEM	DRAWING	DESCRIPTION	QTY
1		JCBC M6 x 35mm	12
2		SPRING WASHER (M6)	12
3		FLAT WASHER (M6 x 13)	12
4		WOOD DOWEL (Ø8 x 30)	8
5		PANHEAD SCREW (M4 x 30mm)	29
6		ALLEN KEY (M4)	1
7		PANHEAD SCREW (M4 x 12mm)	5

**STEP 1** Attached Side Rails (C) to Headboard (A) and Footboard (B) by using the Flat Washer (3), Spring Washer (2), Allen Bolt (1), and tighten with Allen Key (6).

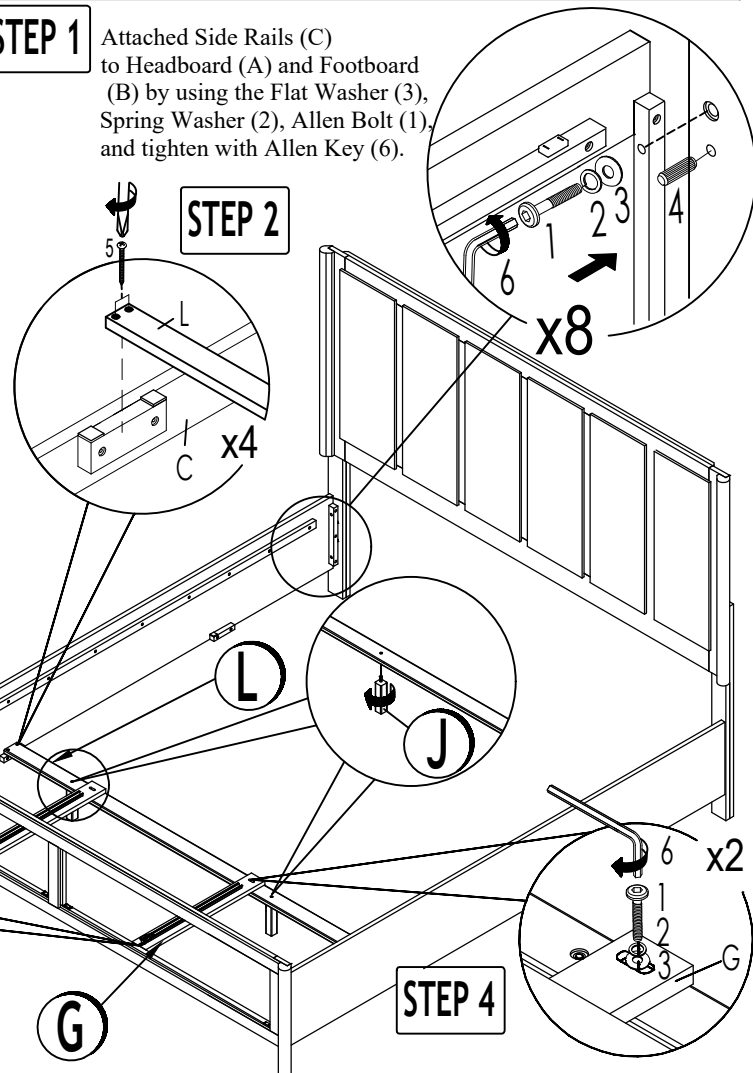

## CLEANING INSTRUCTIONS:

If necessary, clean & polish all surfaces after assembly with a soft cloth and industrial furniture polish.

MADE IN MALAYSIA

# ASSEMBLY INSTRUCTIONS

ITEM NO = C0367A-G3S / C0367A-BTN / C0367A-GXJ  
 DESCRIPTION = KING/CAL.KING STORAGE FOOTBOARD W/12 SLATS, 7 SUPPORTS /  
 QUEEN / KING STORAGE SIDE RAIL SET (2) /  
 KING / CALIFORNIA KING FOOTBOARD DRAWER  
 CASE SET (2), 2 DRAWERS

## STEP 5 BTM. VIEW

Attached Vertical Leg (H) and Vertical Leg (I) to  
 Center Slat (E) and Slat (D)

H

H

H

I

H

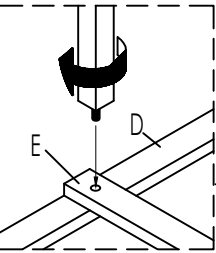

TOP VIEW

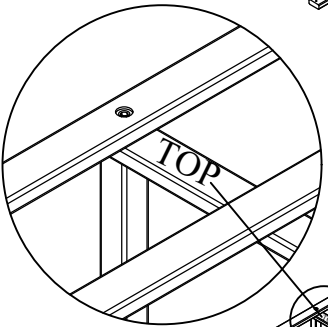

## STEP 6

Attached Slat (D) to  
 Side Rail (C)  
 with Panhead Screw  
 (5), and tighten with  
 Screw Driver.

x24

5

5

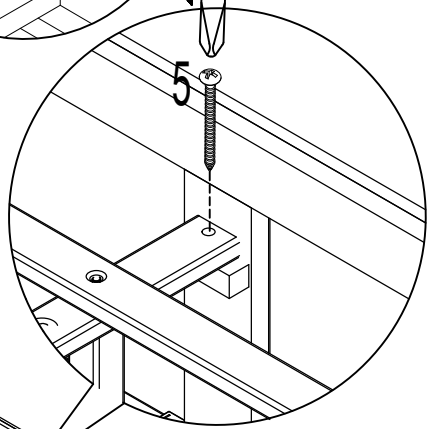
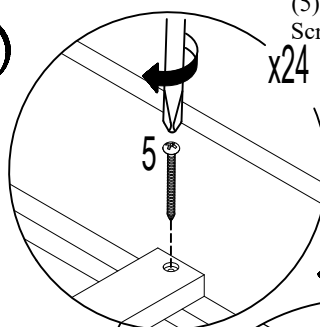

## STEP 7 TOP VIEW

Attached Center Slat (E) to wood  
 holder by using the Panhead Screw  
 (5) and tighten with screw driver.

C

D

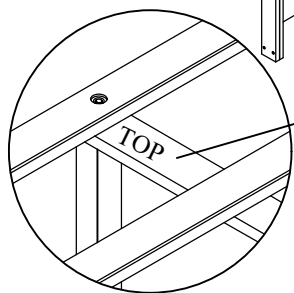

NOTE: SCREWS LOOSEN WITH USE.  
 CHECK FOR LOOSE SCREWS AND TIGHTEN EVERY 6-8 WEEKS

### CLEANING INSTRUCTIONS:

If necessary, clean & polish all surfaces after assembly with a soft cloth and industrial furniture polish.

MADE IN MALAYSIA

# ASSEMBLY INSTRUCTIONS

ITEM NO = C0367A-G3S / C0367A-BTN / C0367A-GXJ  
DESCRIPTION = KING/CAL.KING STORAGE FOOTBOARD W/12 SLATS, 7 SUPPORTS /  
QUEEN / KING STORAGE SIDE RAIL SET (2) /  
KING / CALIFORNIA KING FOOTBOARD DRAWER  
CASE SET (2), 2 DRAWERS

## STEP 9

Unscrewing the handle screw from outside, take out the handle from the drawer and install handle at drawer front

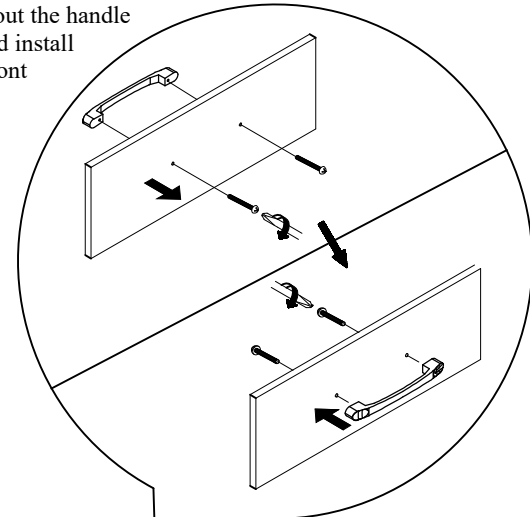

## STEP 8

Attached Decking Board (K) to Slat (D), from below with Panhead Screw (7), and tighten with Screw Driver.

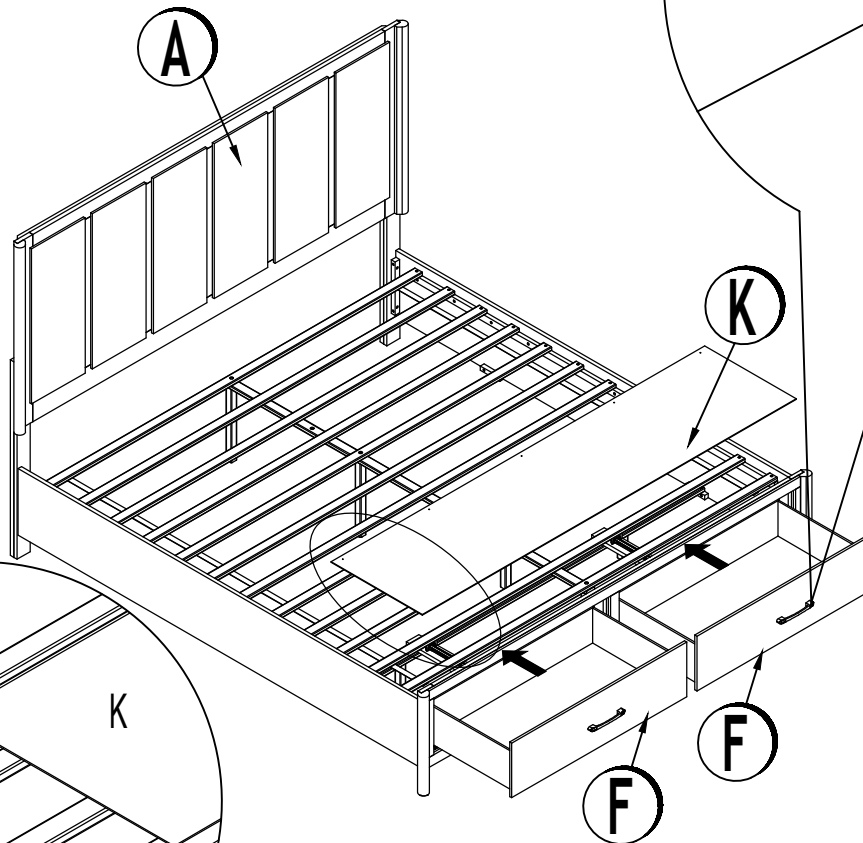
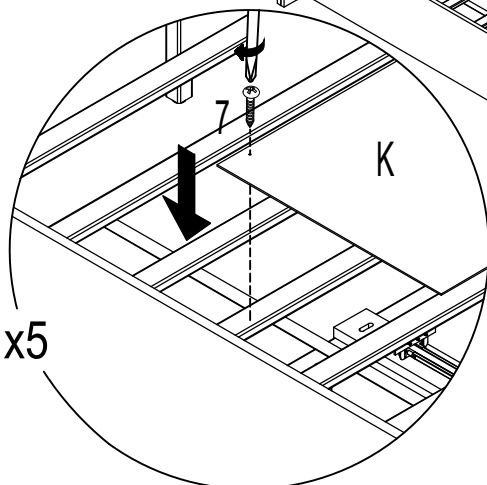

COMPLETED  
ASSEMBLY

NOTE: SCREWS LOOSEN WITH USE.  
CHECK FOR LOOSE SCREWS AND TIGHTEN EVERY 6-8 WEEKS

### CLEANING INSTRUCTIONS:

If necessary, clean & polish all surfaces after assembly with a soft cloth and industrial furniture polish.

MADE IN MALAYSIA