

ASSEMBLY INSTRUCTIONS

Important Safety Instructions:

- Please read all instructions before beginning assembly
- Please make sure receive all the parcels to start the assembly
- For your safety and convenience, assembly by two people is recommended
- Use the parts and hardware lists to identify and separate each of the components included
- Save all packing materials until assembly is completed to avoid the accidental discarding of smaller parts or hardware

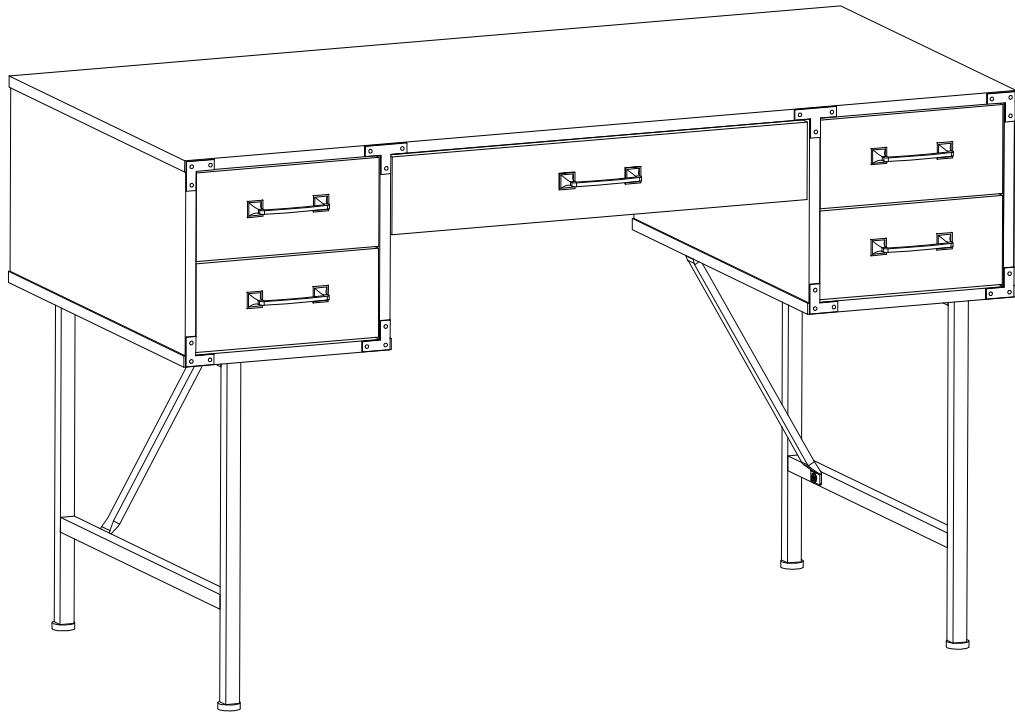







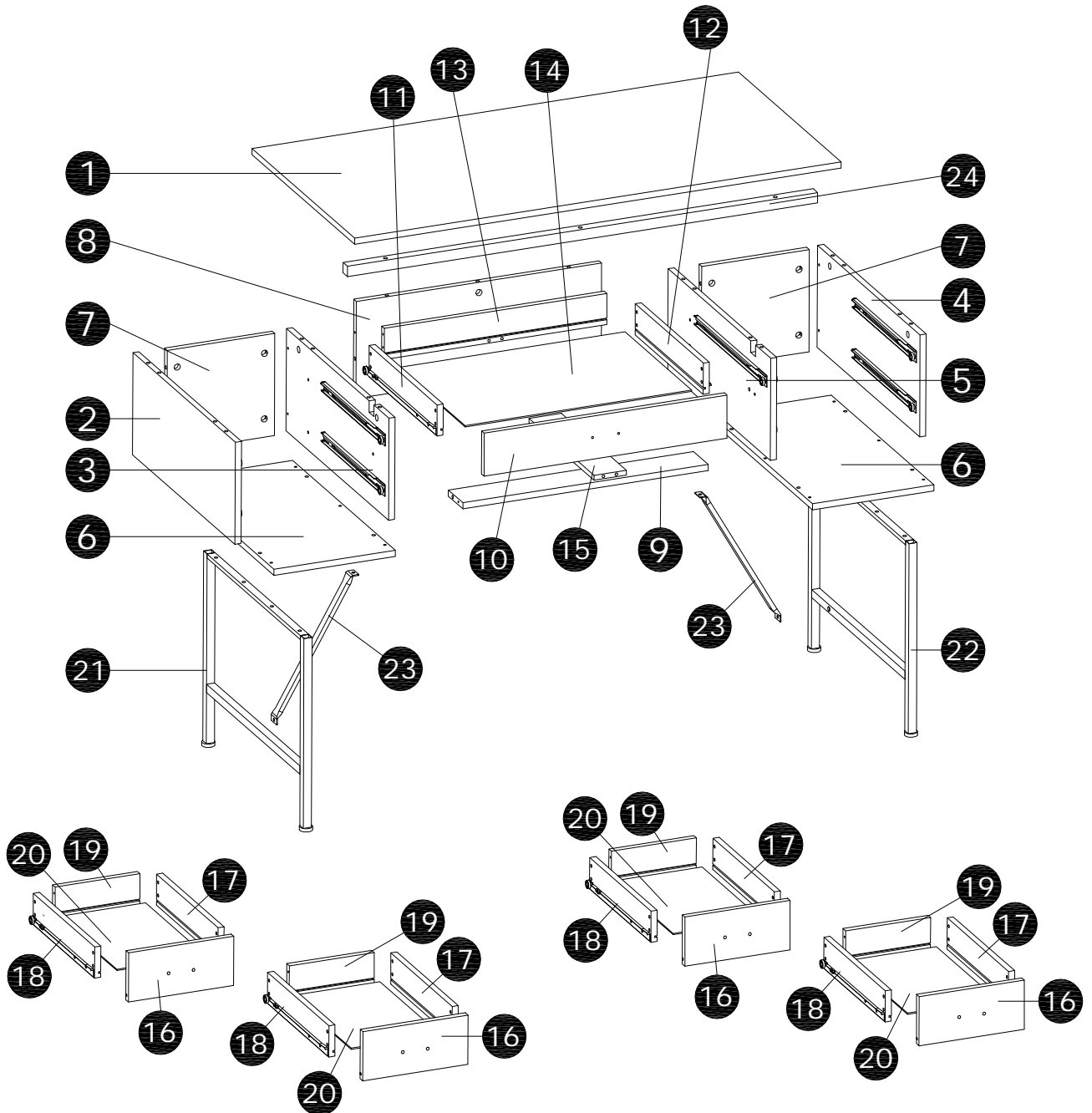

THANK YOU FOR PURCHASING



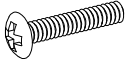
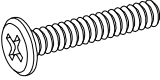
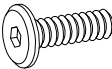

PARTS LIST

1 X1	2 X1	3 X1	4 X1	5 X1
6 X2	7 X2	8 X1	9 X1	10 X1
11 X1	12 X1	13 X1	14 X1	15 X1
16 X4	17 X4	18 X4	19 X4	20 X4
21 X1	22 X1	23 X2	24 X1	

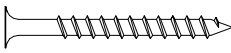

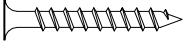
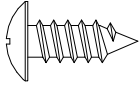
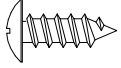
HARDWARE LIST

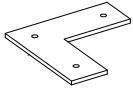
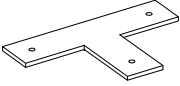
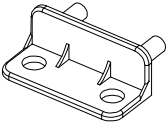
Name	Part	Qty.	Spare
A		17	1
B		17	1
C		2	1
D		2	1
E		4	
F		5	
G		10	1
H		3	
I		8	
J		2	
K		18	

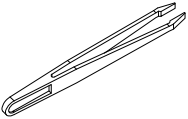
Name	Part	Qty.	Spare
L		22	
M	 9/16" Screw	22	1
N	 1/2" Screw	20	1
O		48	2
P		12	
Q		4	
R		10	
S		22	1
T		1	
V		1	

STEP 1

A x8pcs

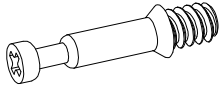

S x16pcs

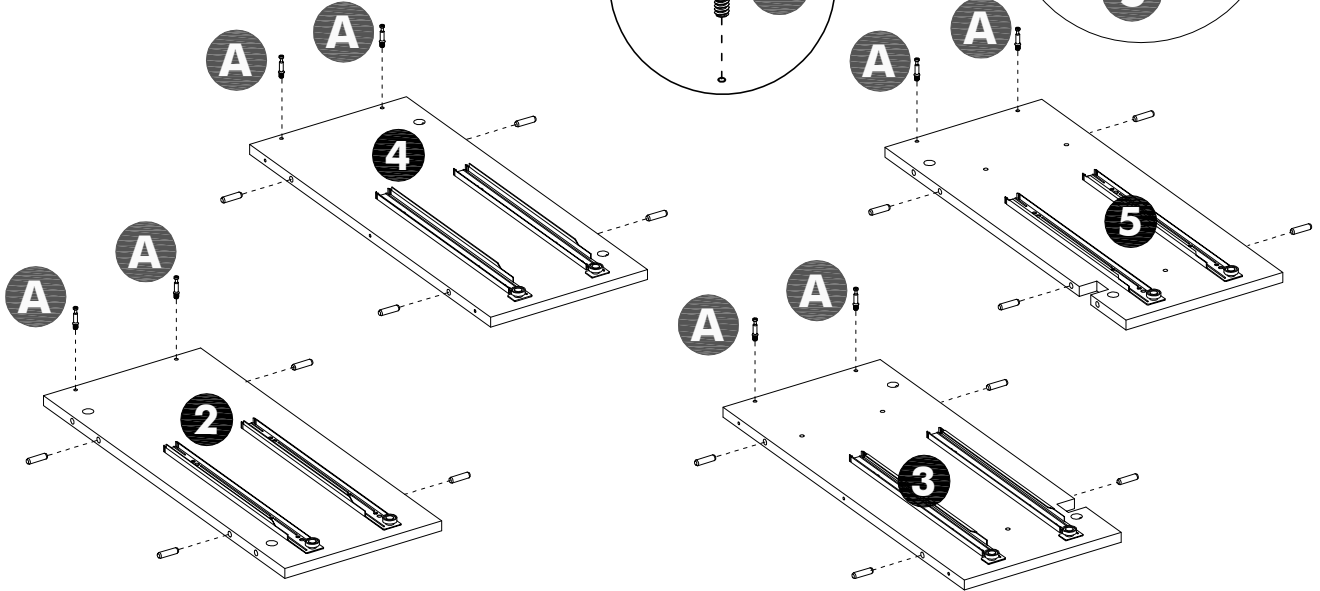
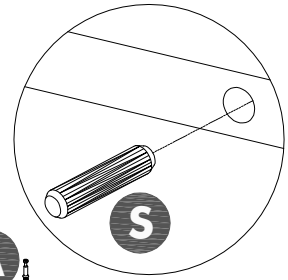
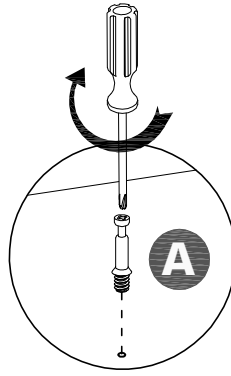
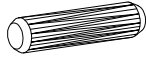

STEP 2

S x6pcs

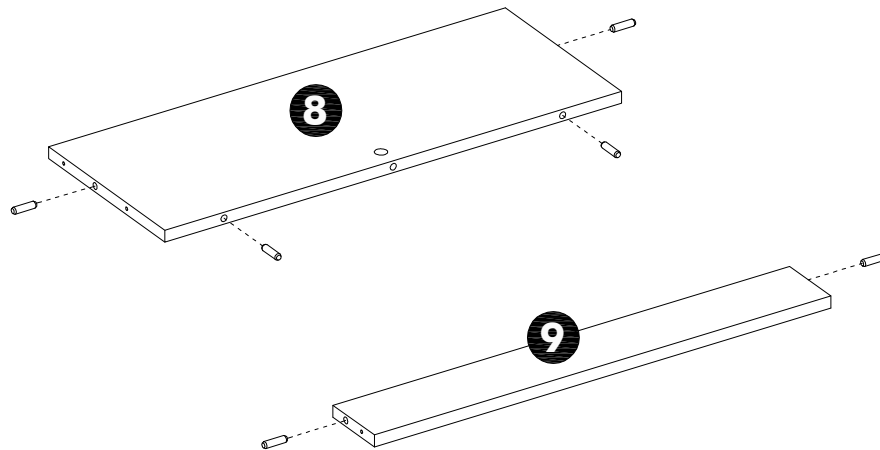
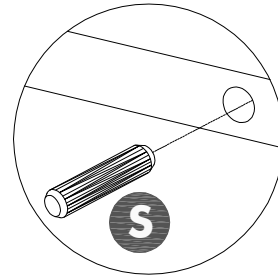

STEP 3

K x6pcs

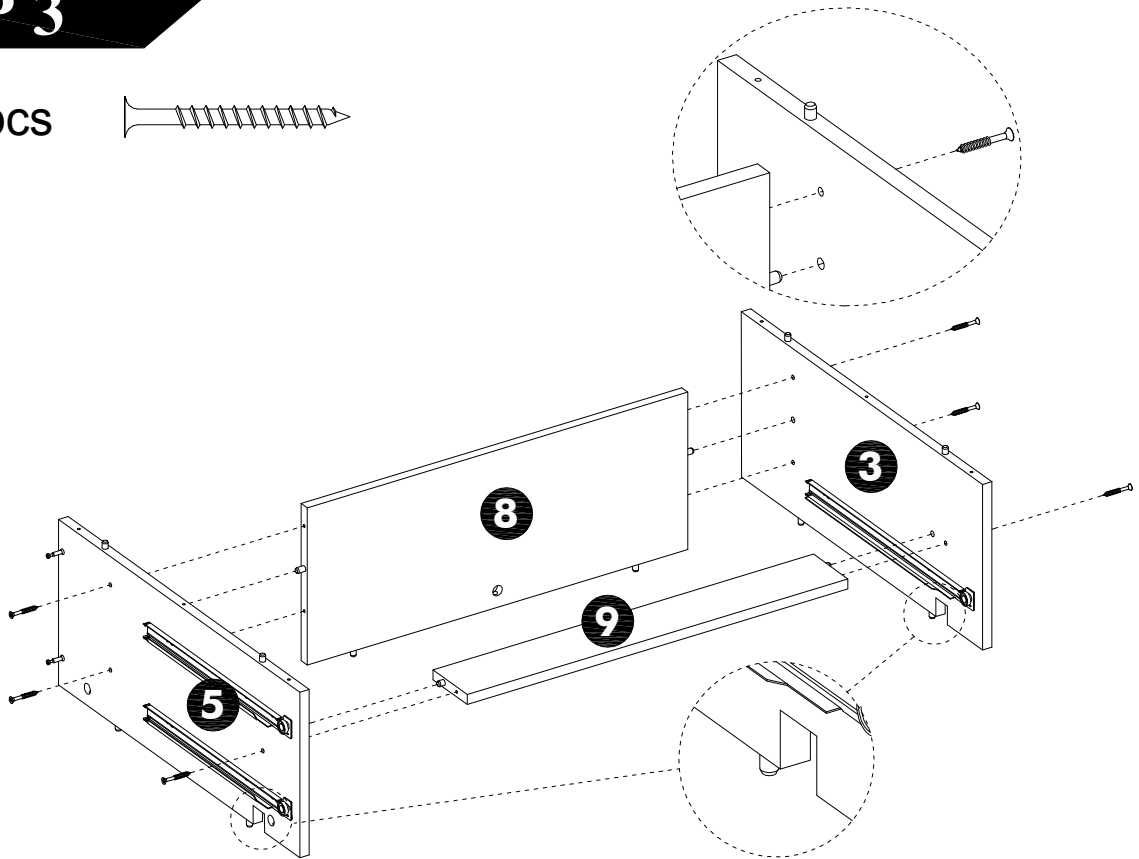
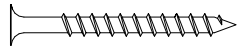

STEP 4

B x2pcs

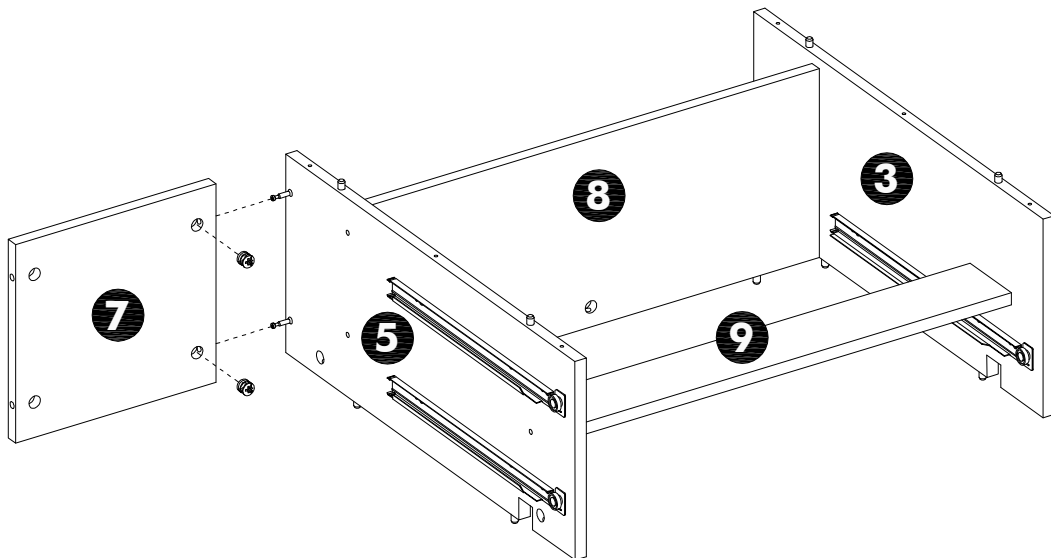
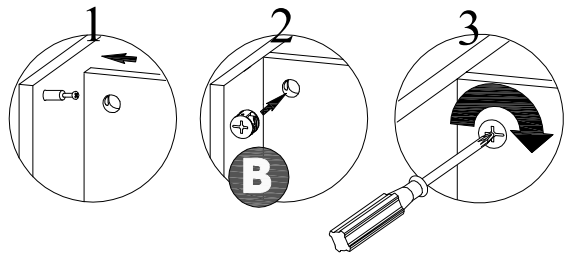

STEP 5

B x2pcs

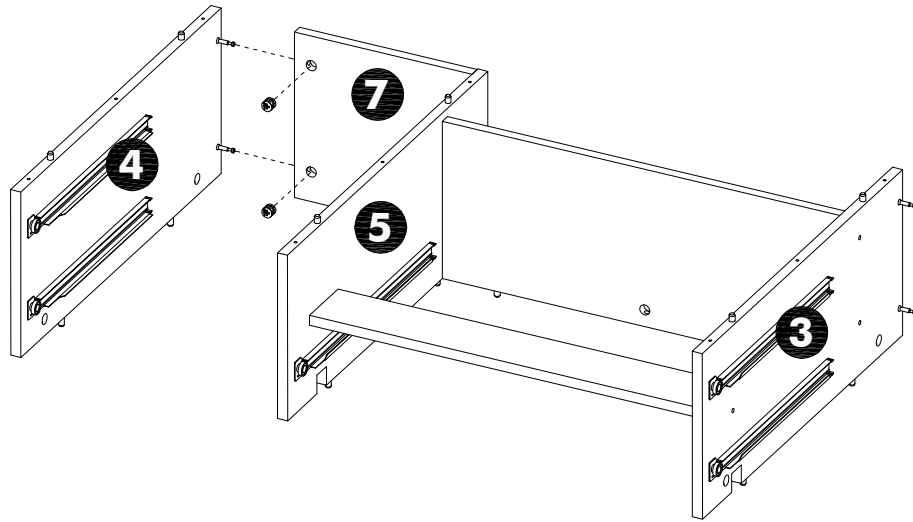
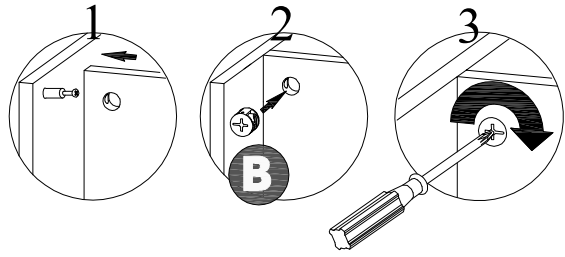
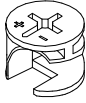

STEP 6

B x2pcs

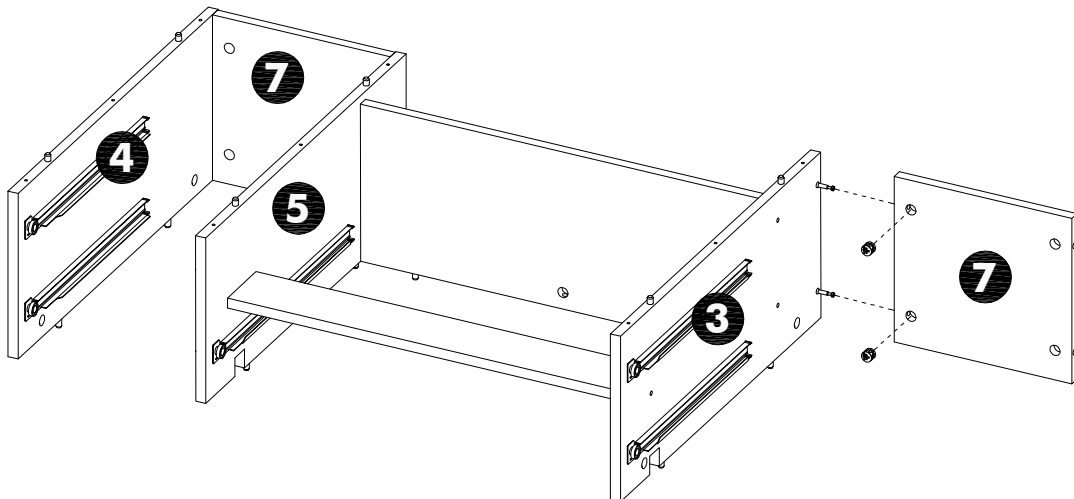
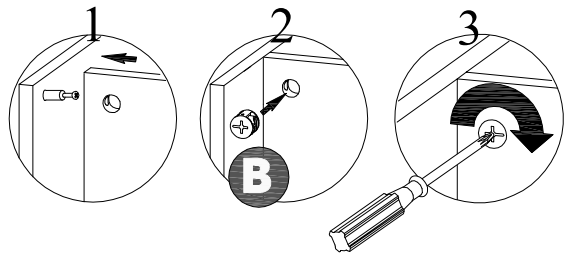

STEP 7

B x2pcs

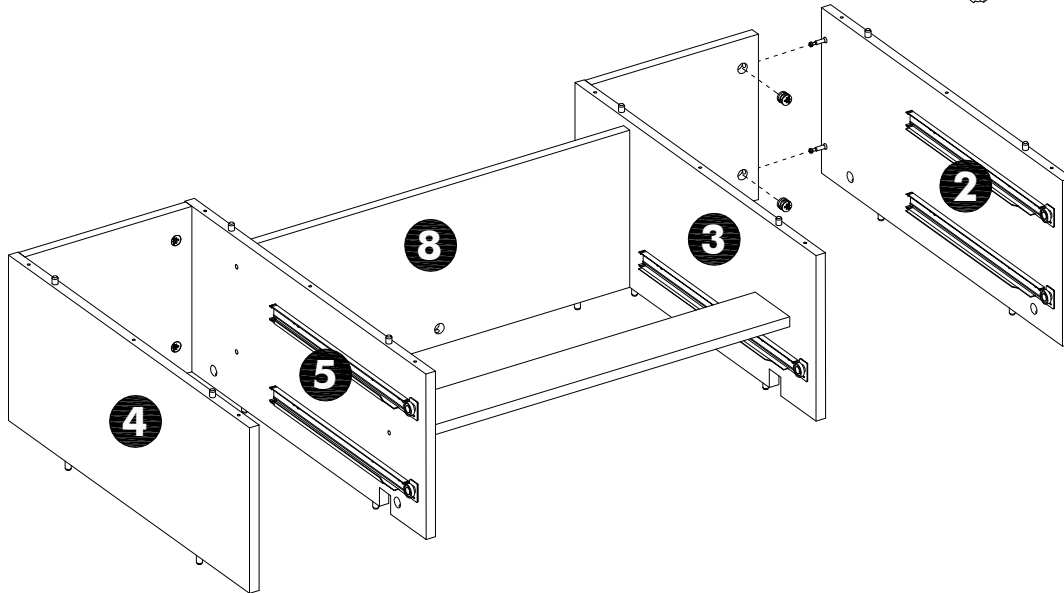
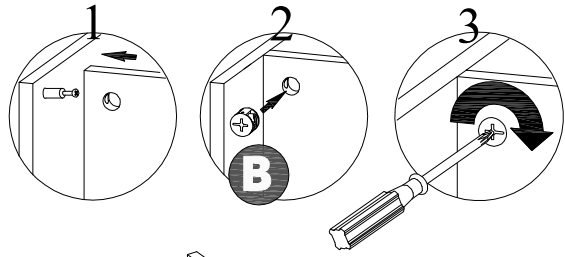

STEP 8

H x3pcs

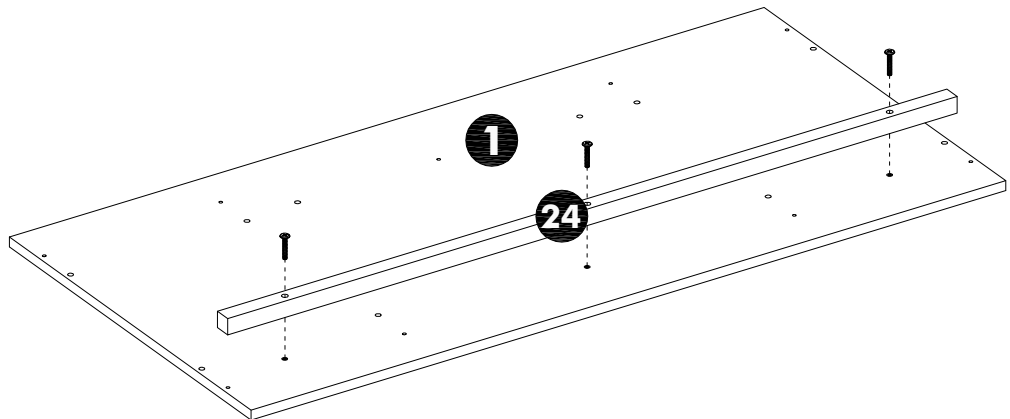
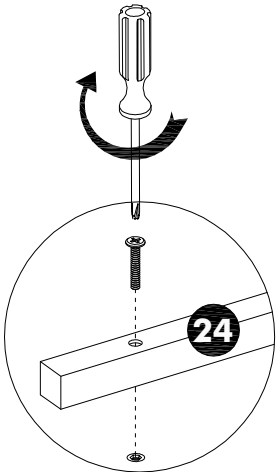
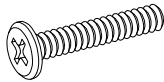

STEP 9

A x9pcs

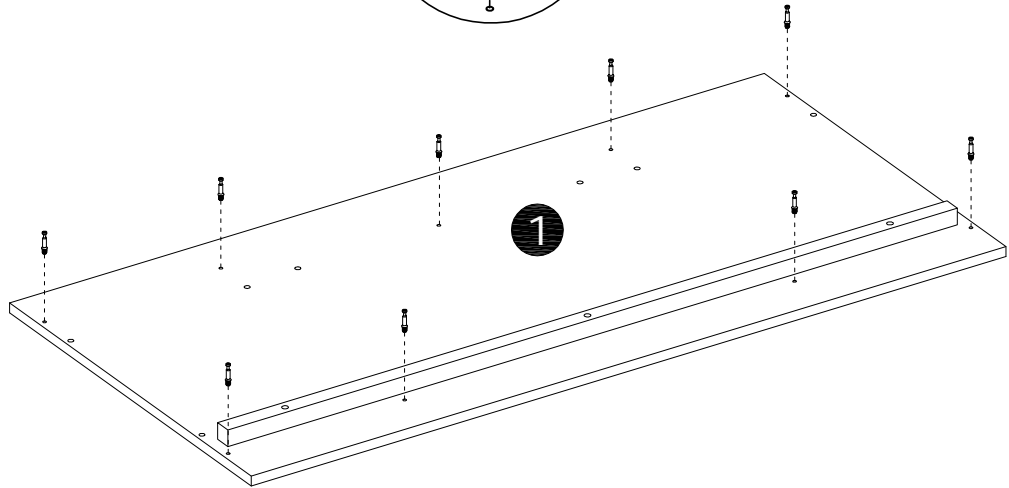
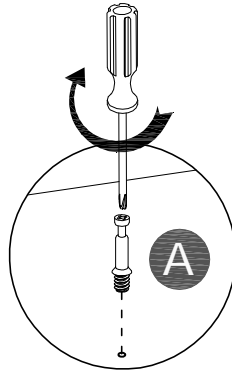
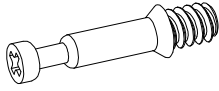

STEP 10

B x9pcs

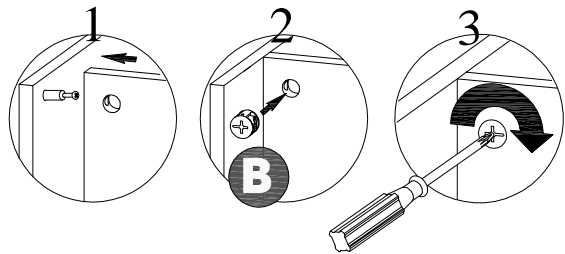

An assistant is required.

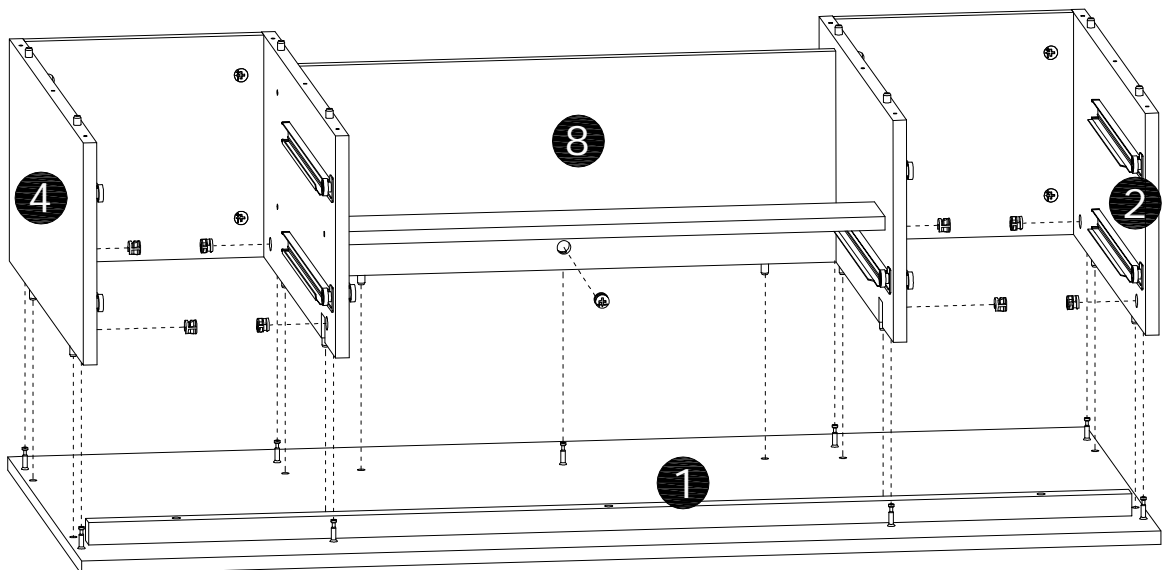

STEP 11

K x12pcs 

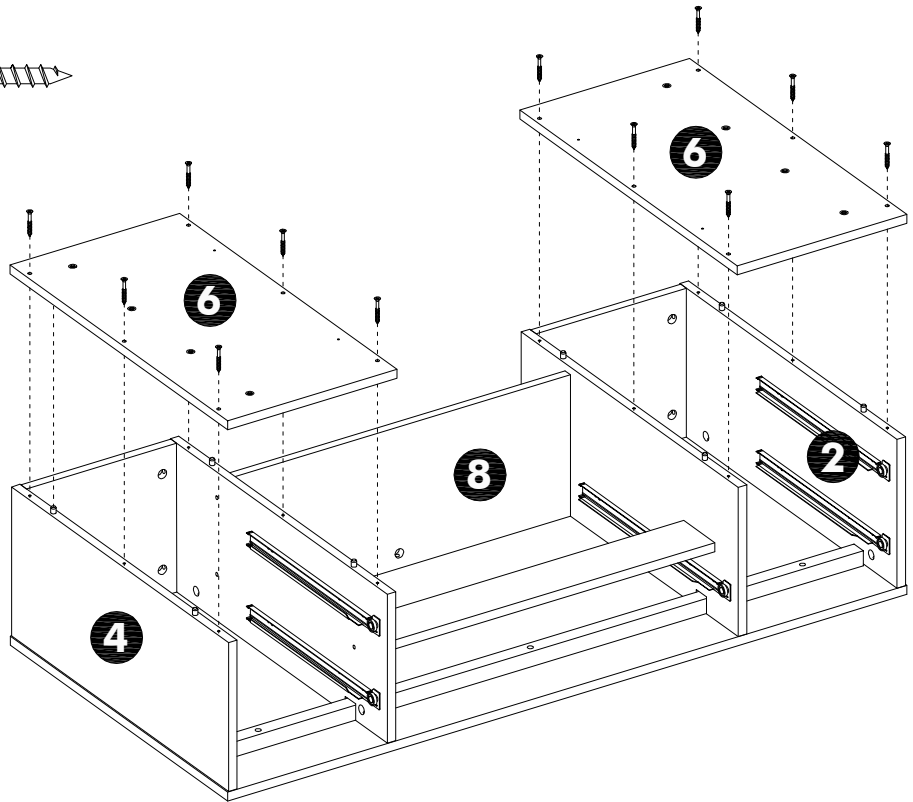
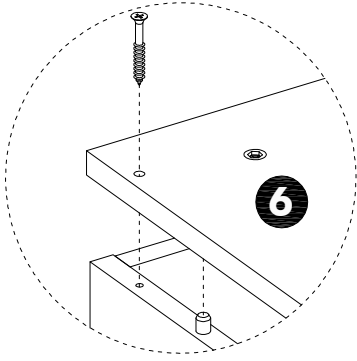

STEP 12

I x8pcs 

T x1pcs 

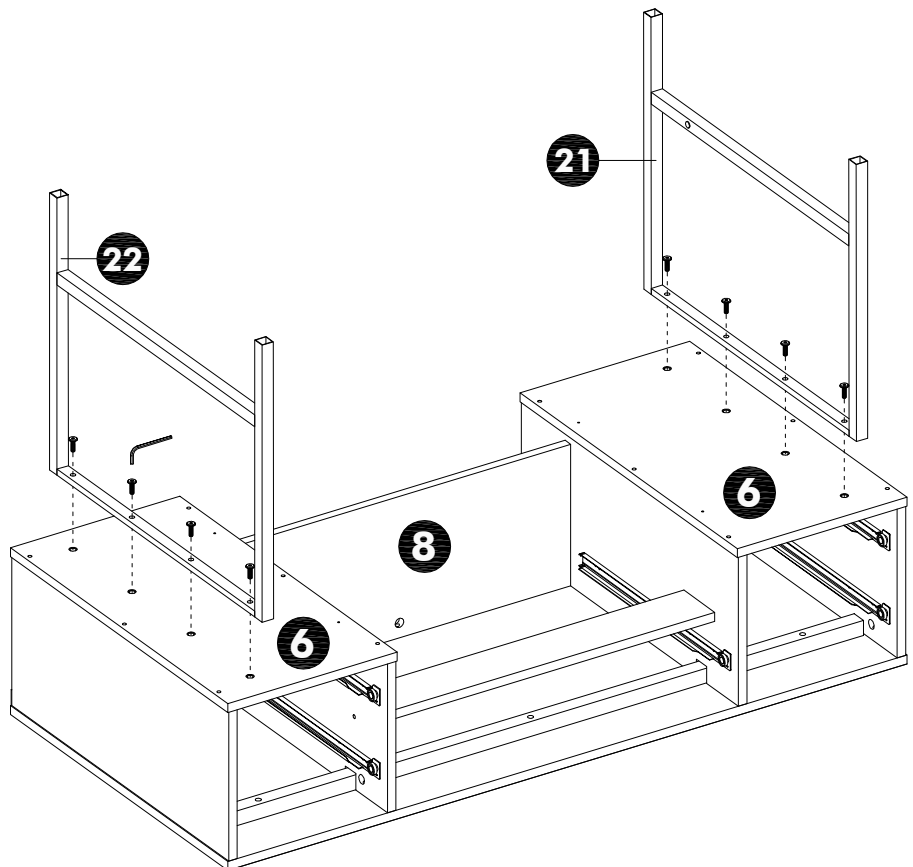
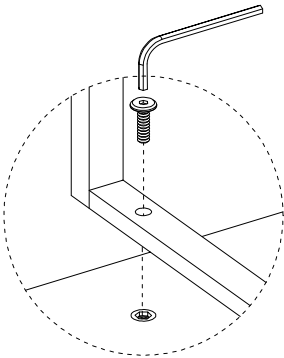

STEP 13

J x2pcs 

M x2pcs 

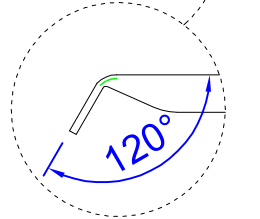
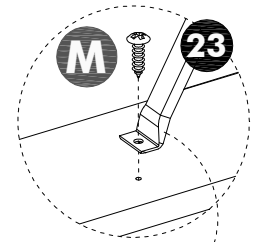
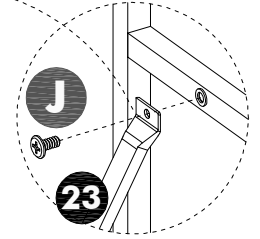
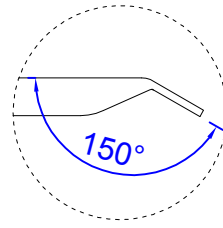
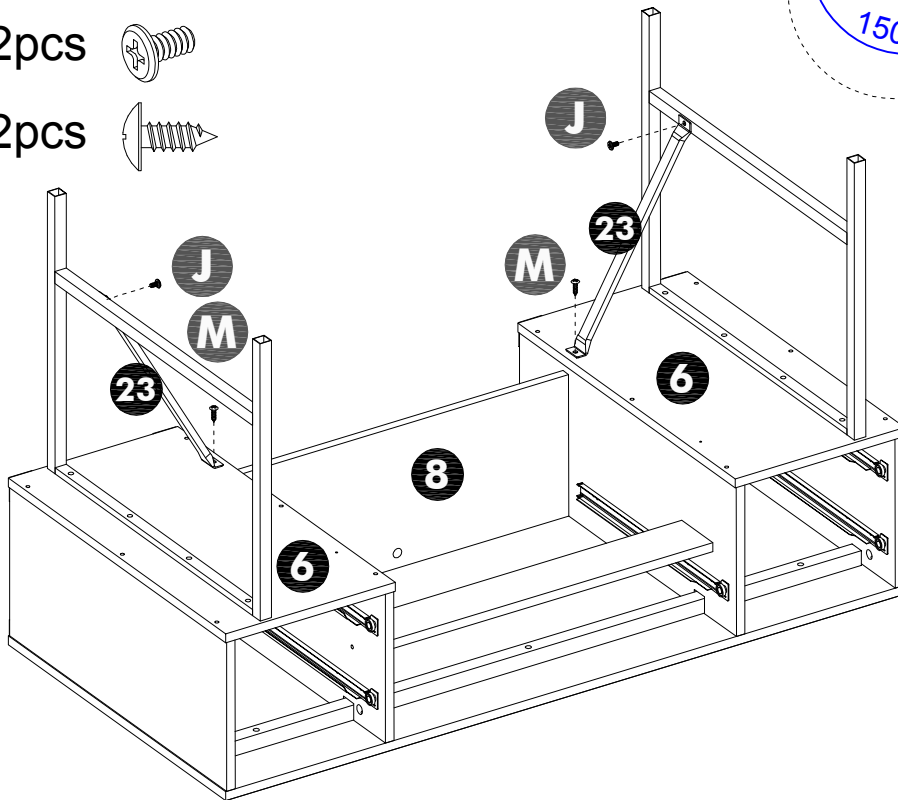

STEP 14

E x4pcs 

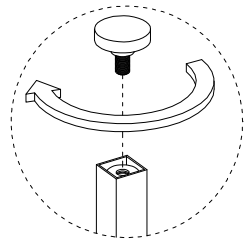
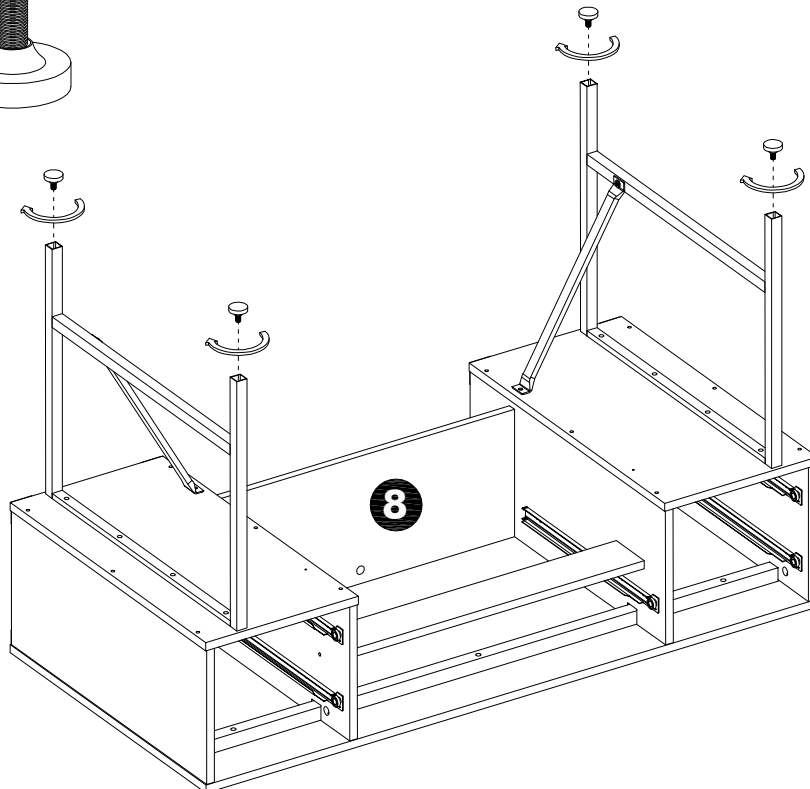

STEP 15

With assistant carefully flip unit over.

Peel off the adhesive sticker's protective paper and bond it onto the designated position before secure with nails.

P x6pcs

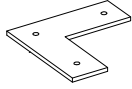

Q x2pcs

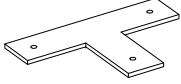

O x24pcs



V x1pcs

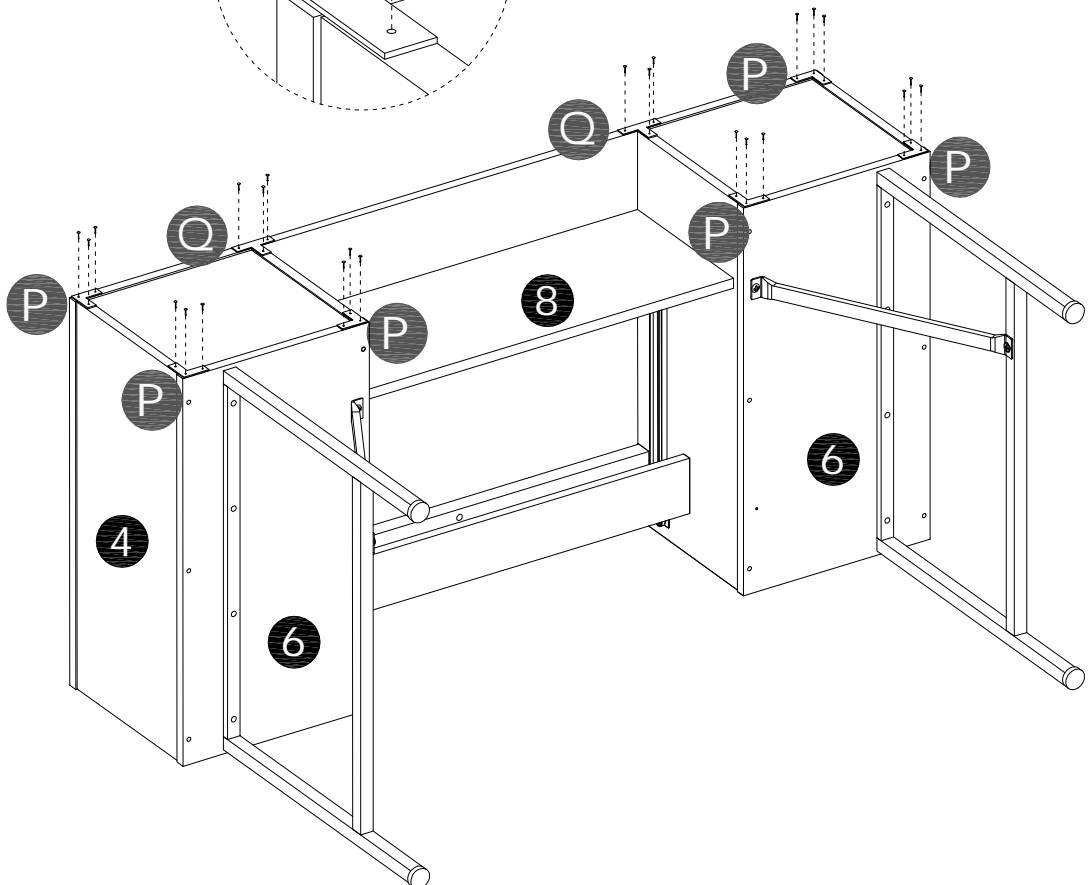
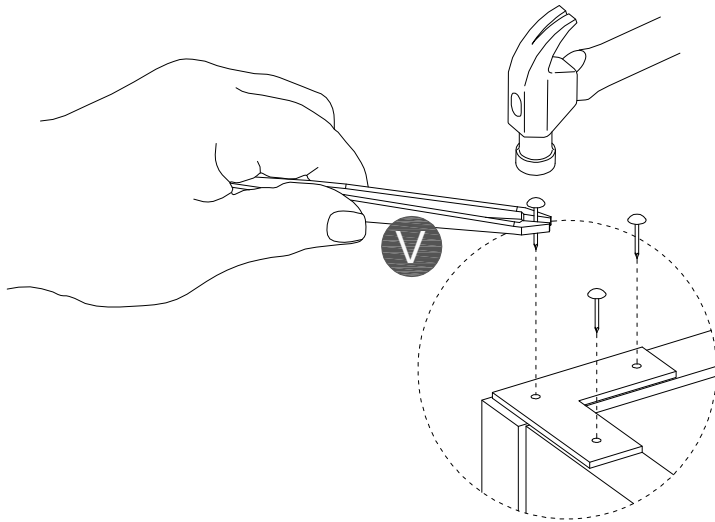
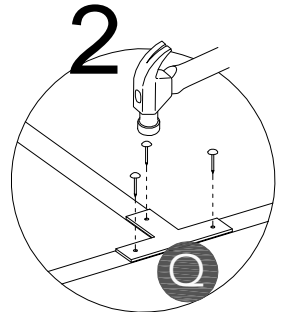
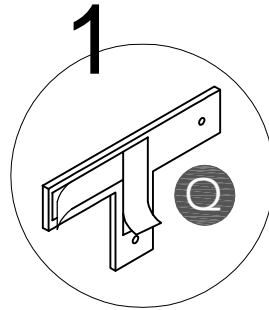
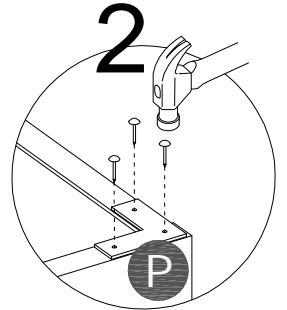
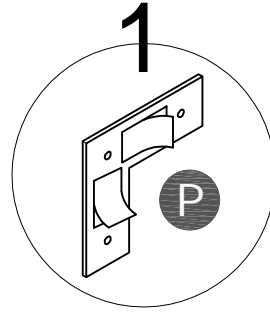
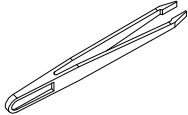

STEP 16

P x6pcs

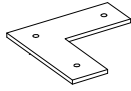

Q x2pcs

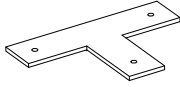

O x24pcs



V x1pcs

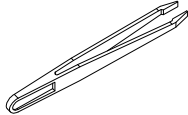

With assistant carefully flip unit over.

Peel off the adhesive sticker's protective paper and bond it onto the designated position before secure with nails.

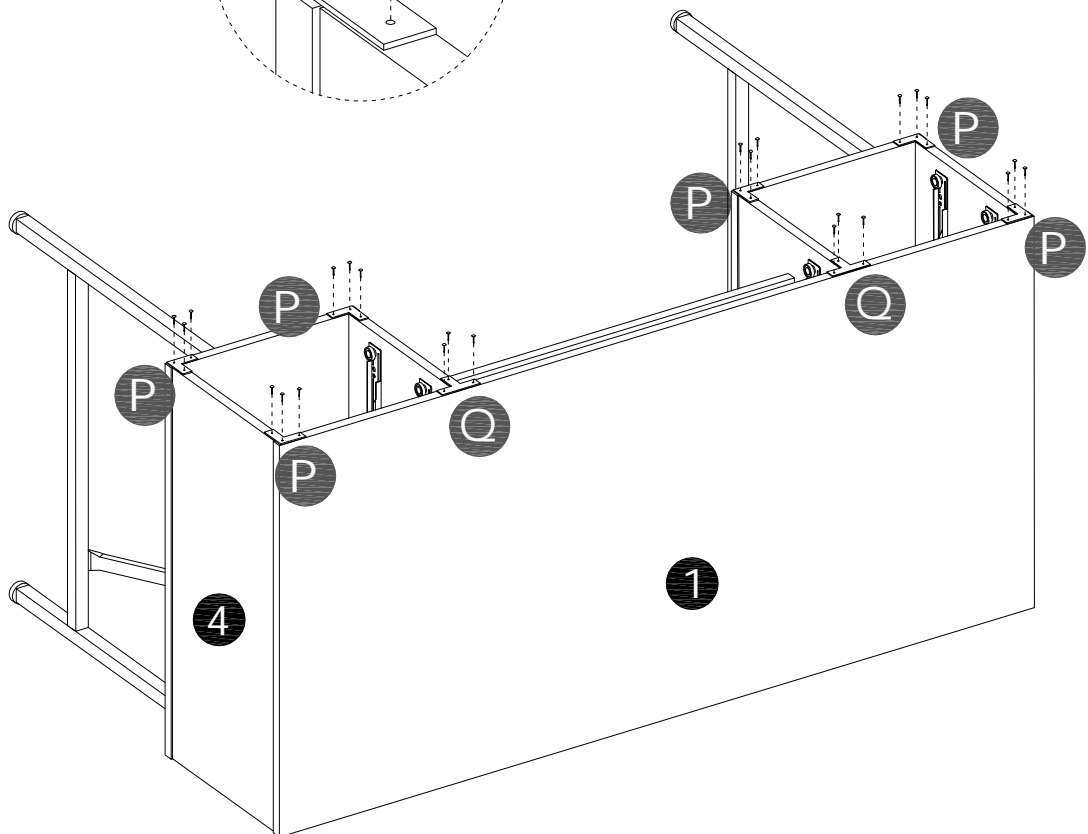
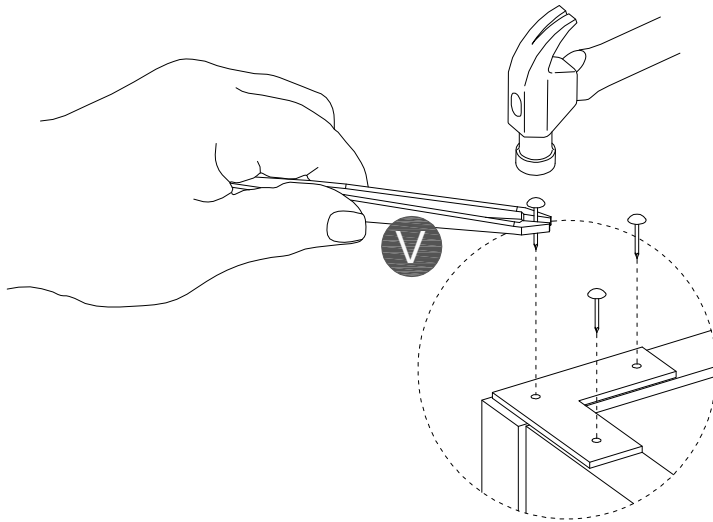
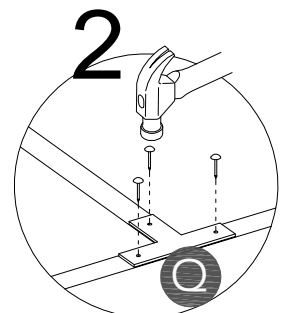
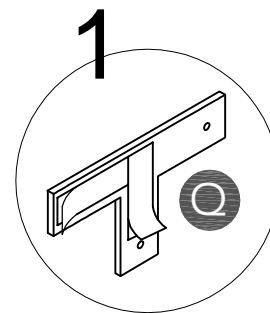
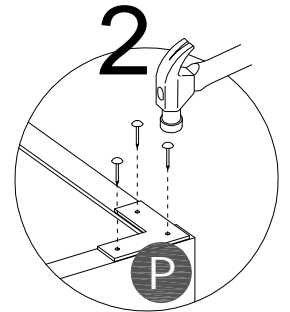
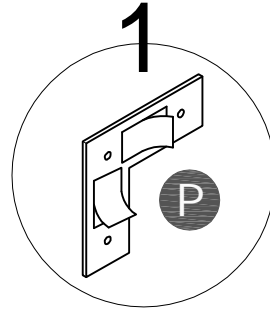

STEP 17

R x8pcs

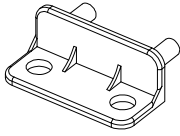

M x16pcs

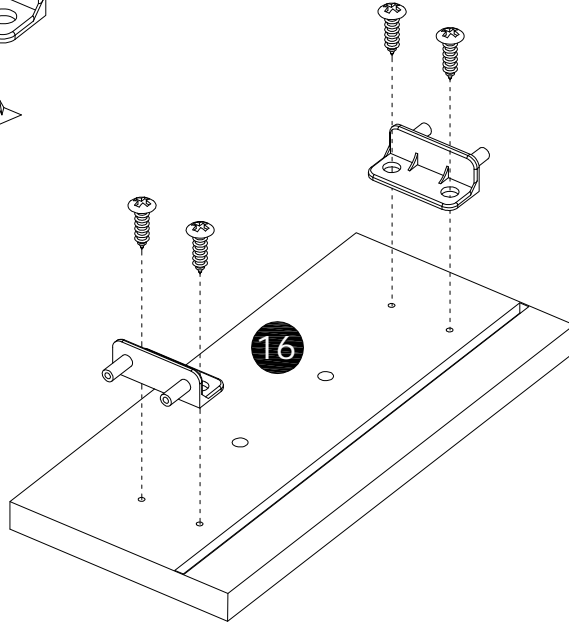
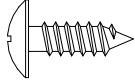

x4

STEP 18

N x16pcs

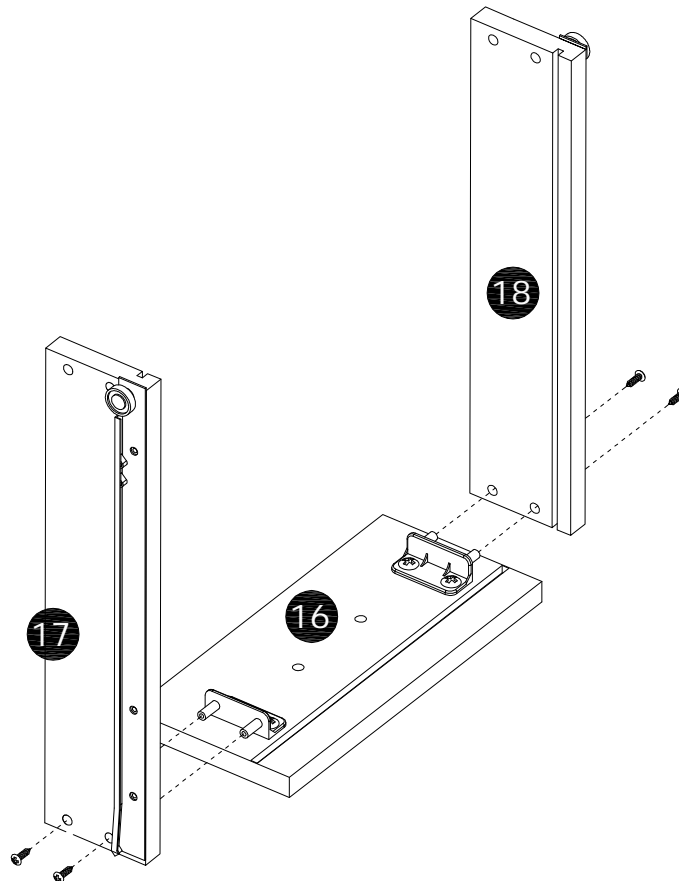
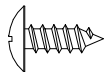

x4

STEP 19

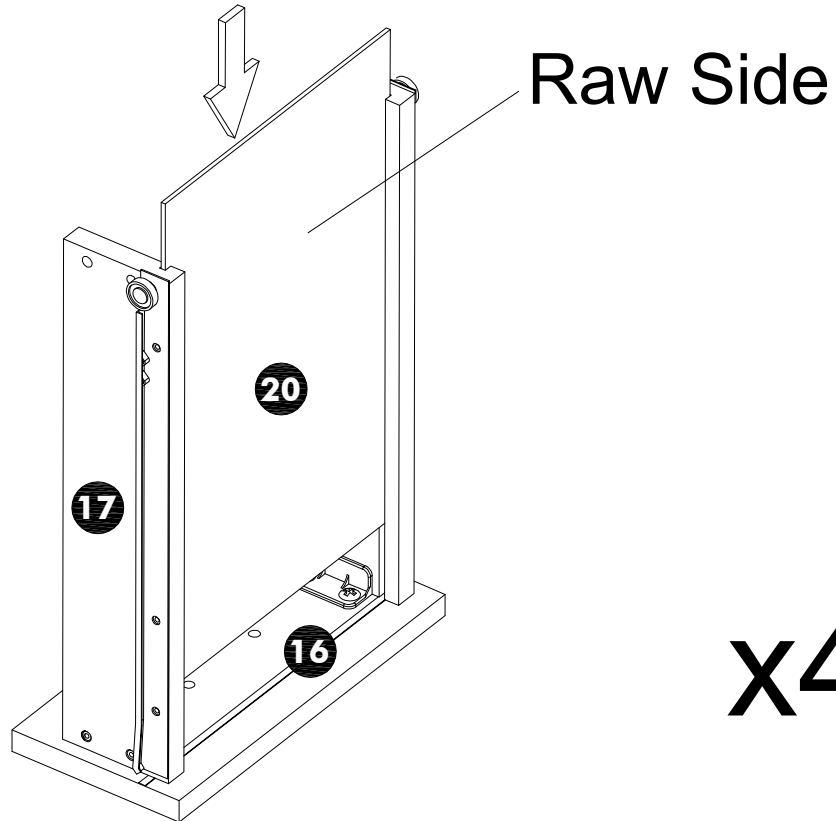

STEP 20

L x16pcs 

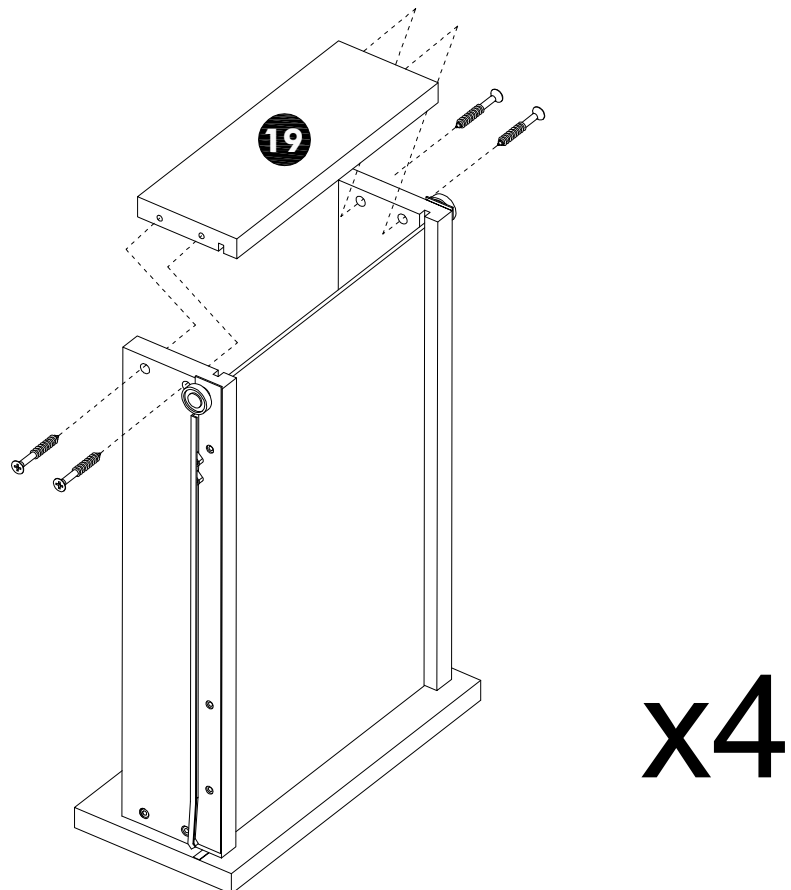

STEP 21

F x4pcs



G x8pcs

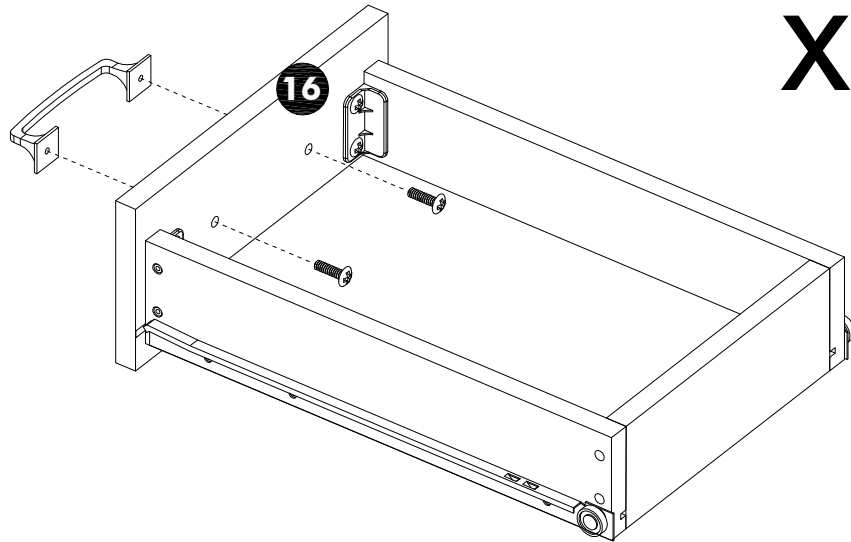
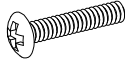

x4

STEP 22

R x2pcs

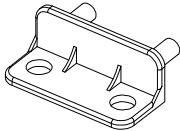

M x4pcs

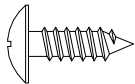

C x2pcs

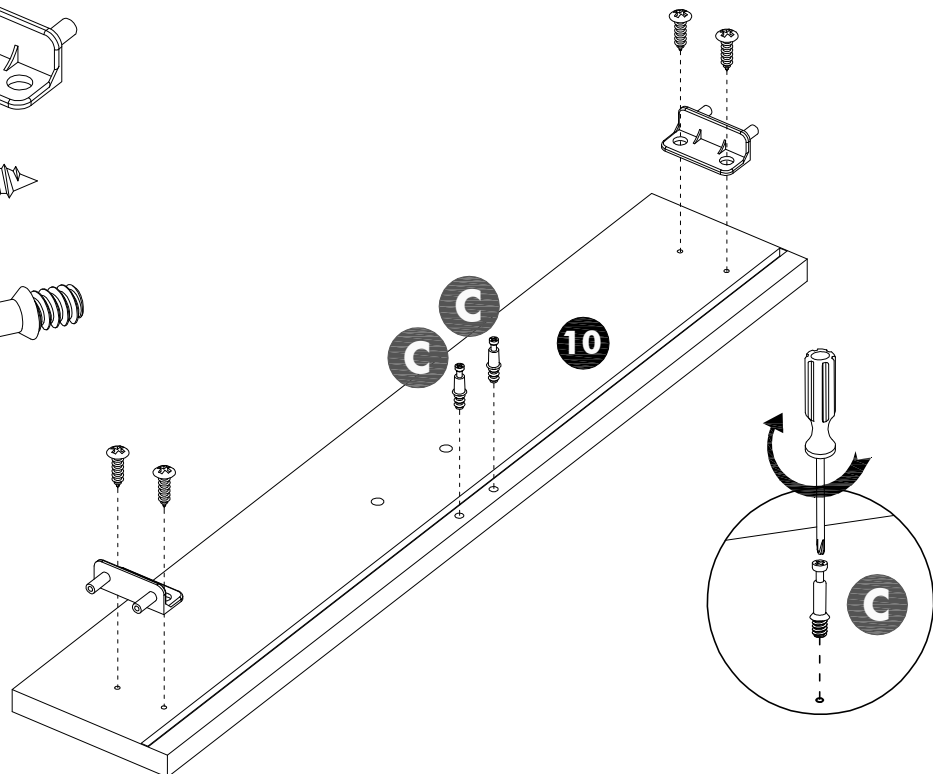
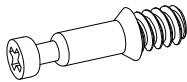

STEP 23

N x4pcs 

D x2pcs 

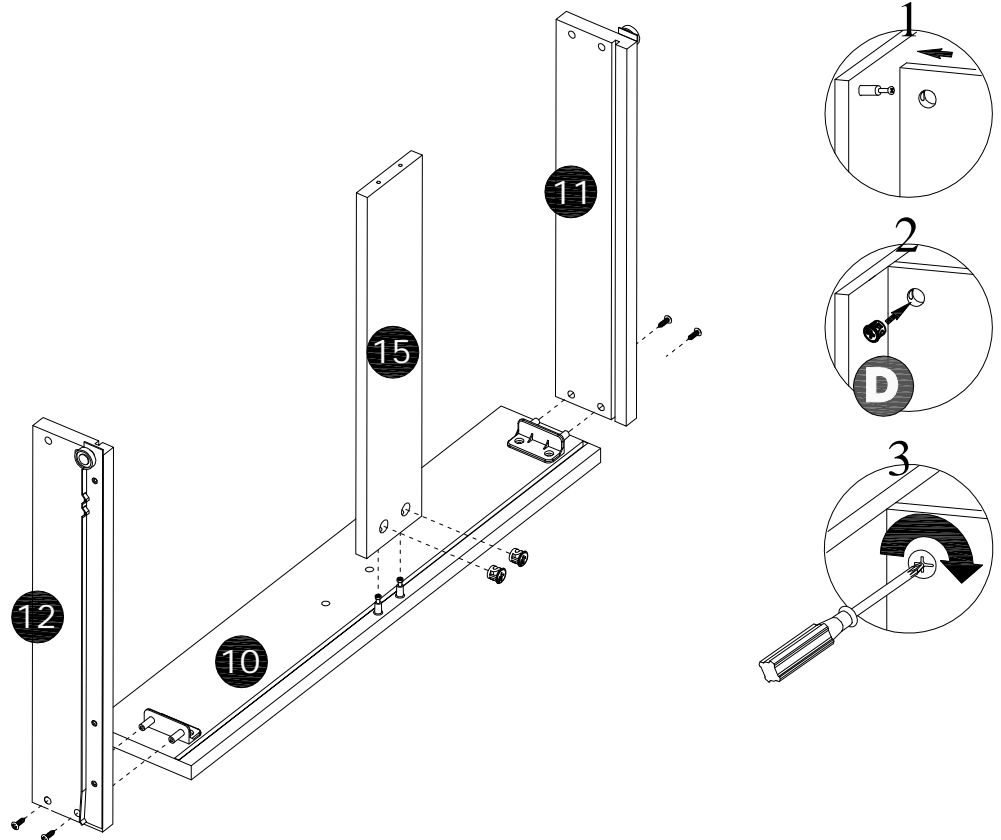

STEP 24

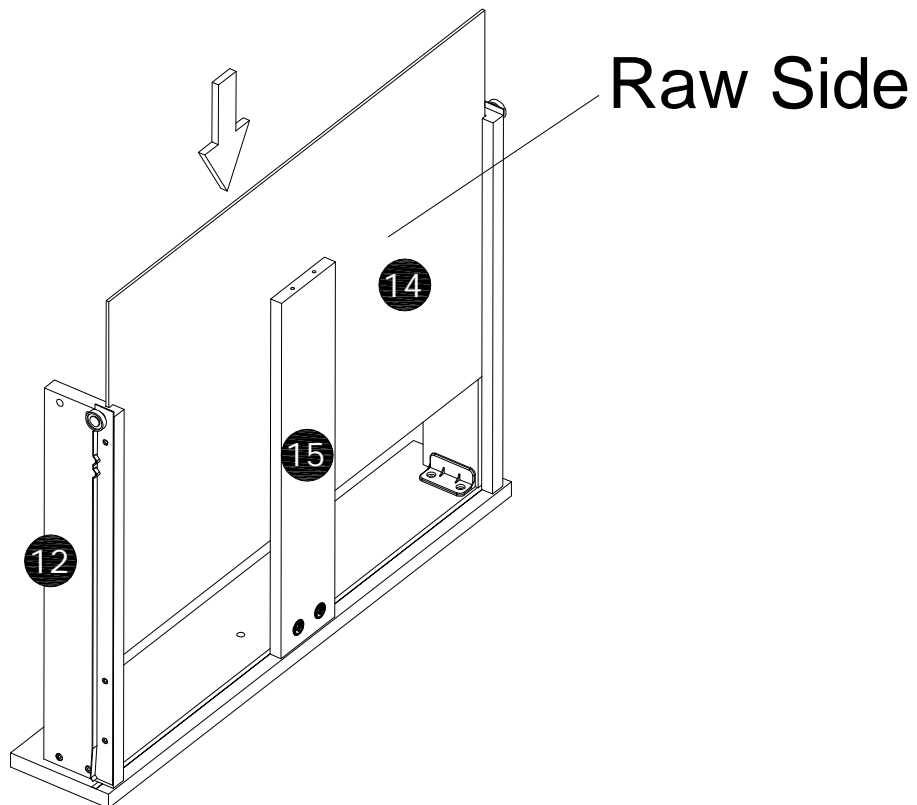

STEP 25

L x6pcs 

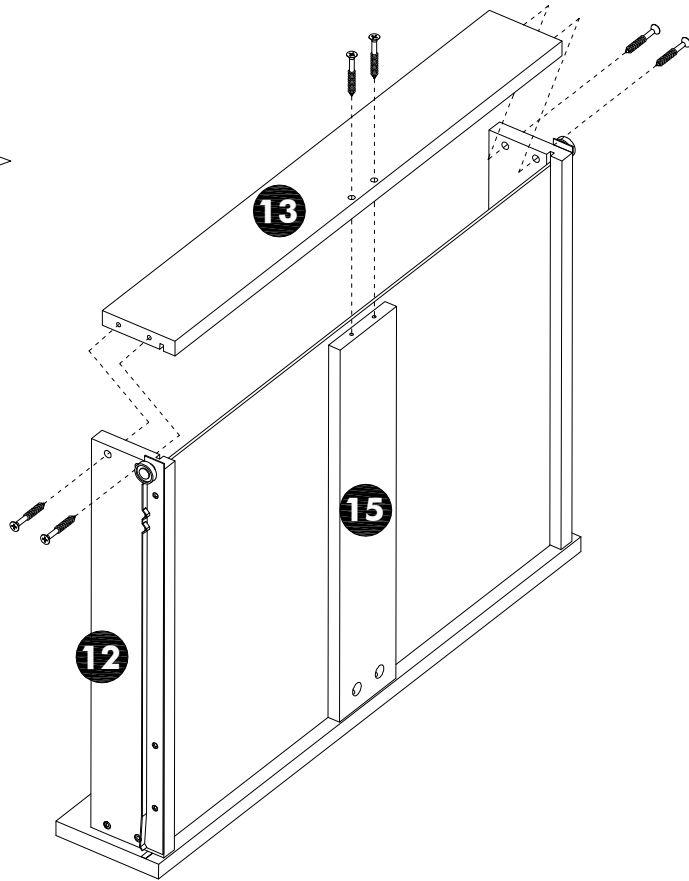

STEP 26

F x1pcs 

G x2pcs 

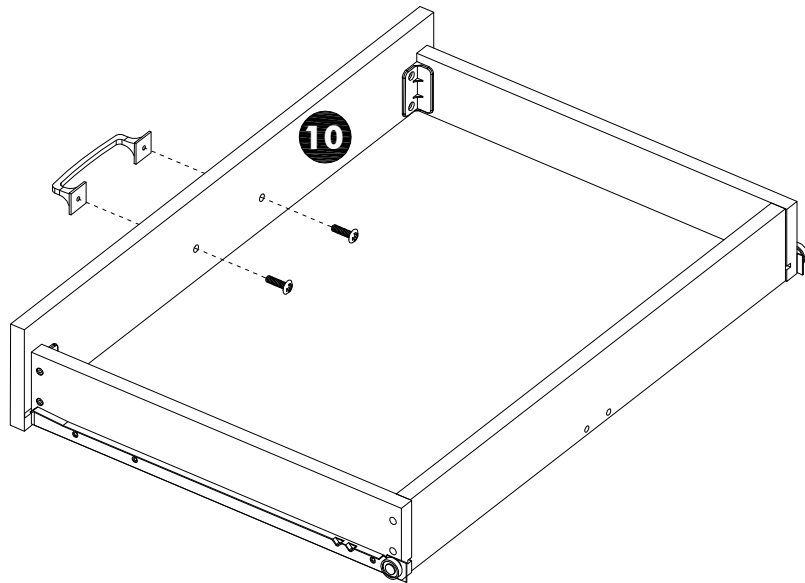

STEP 27

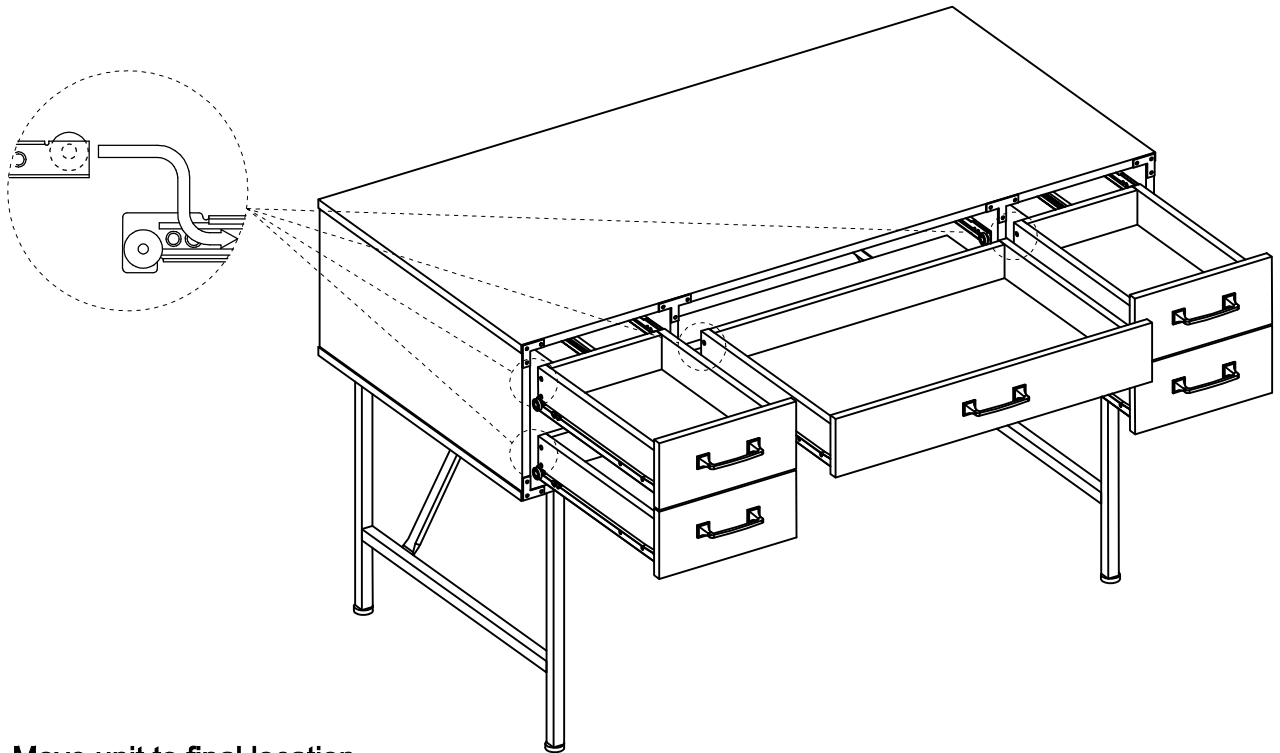

-Move unit to final location.

-Adjust drawer fronts as shown below.

Step1--Loosen screws on back of drawer front brackets as shown.

Step2--Position drawer front as required.

Step3--Tighten screws while holding drawer front in position.

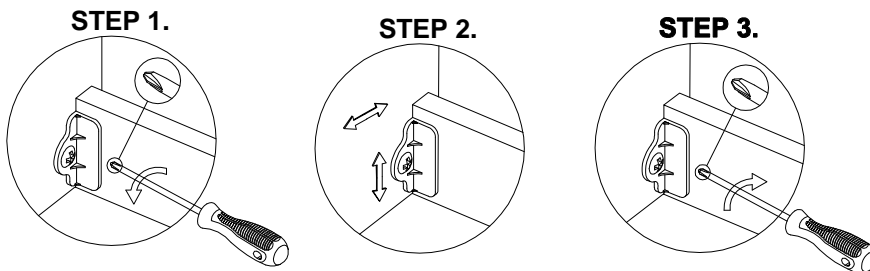

DRAWER FRONT VIEW

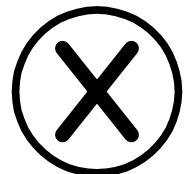
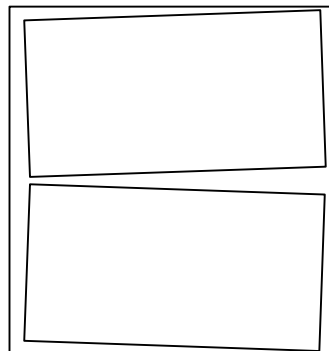
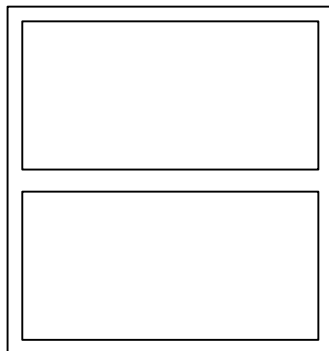

Maximum weight capacities

MAXIMUM WEIGHT: 200 LBS (91KG)

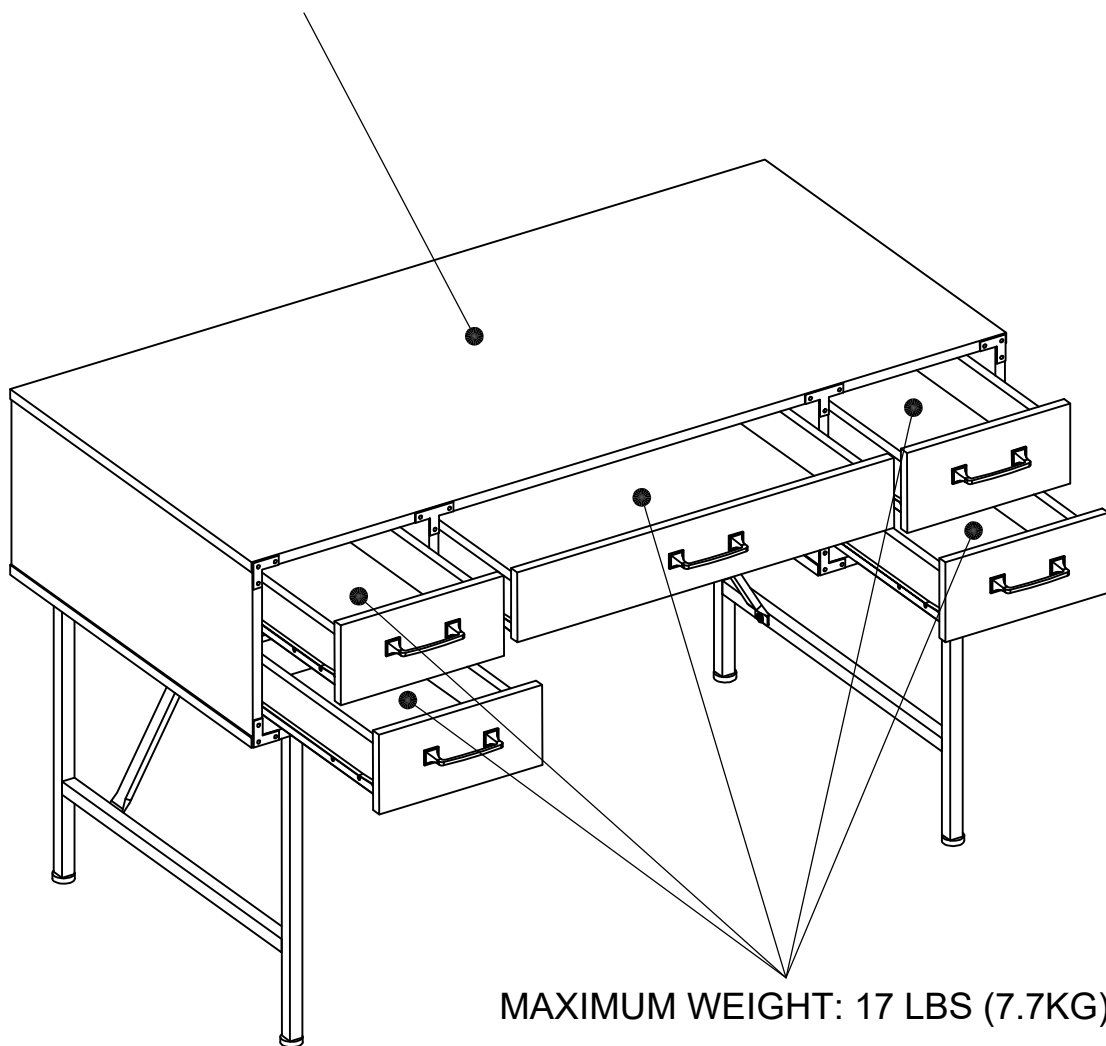

MAXIMUM WEIGHT: 17 LBS (7.7KG)