

Assembly Instructions

Caution: You must read this before you proceed

BARSTOOL

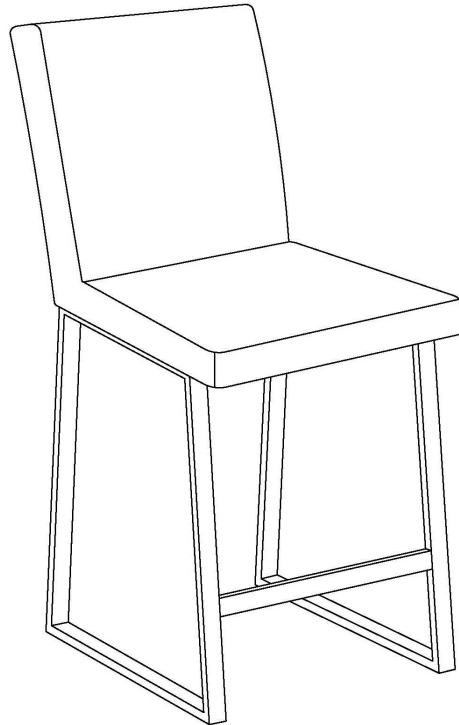



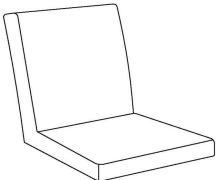
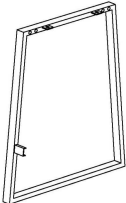

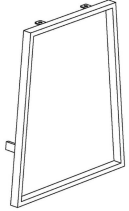
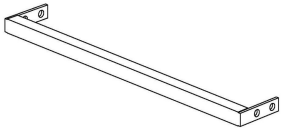
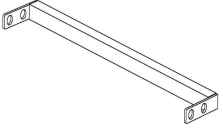
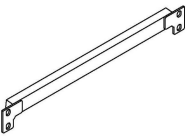
Parts List



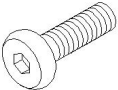



Label	Picture	Description	QTY
A		Chair Seat	1
B		Left Leg (with Adjustable Leveller)	1

C		Right Leg (with Adjustable Leveller)	1
D		Front Rail	1
E		Back Rail	1
F		Front Connecting Rod	1

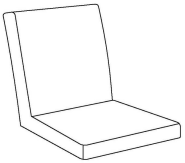
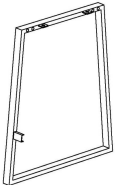
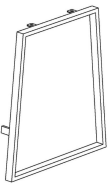
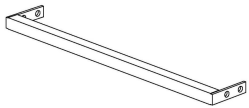
Hardware

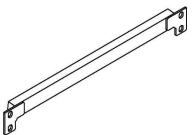
Label	Picture	Description	QTY
①		Bolt (M6*19mm)	21
②		Spring Washer	21
③		Washer	21
④		Allen Wrench	1

Assembly Preparation

Before Beginning Assembly:	         
----------------------------	--



- Read instructions, cover to cover-



- Have 2 adults on hand for assembly-



- Do not assemble on flooring or carpet-



- Assemble on a clean non-marring surface (packing foam)-



- Save all packaging until finished-

Assembly Steps

Overview

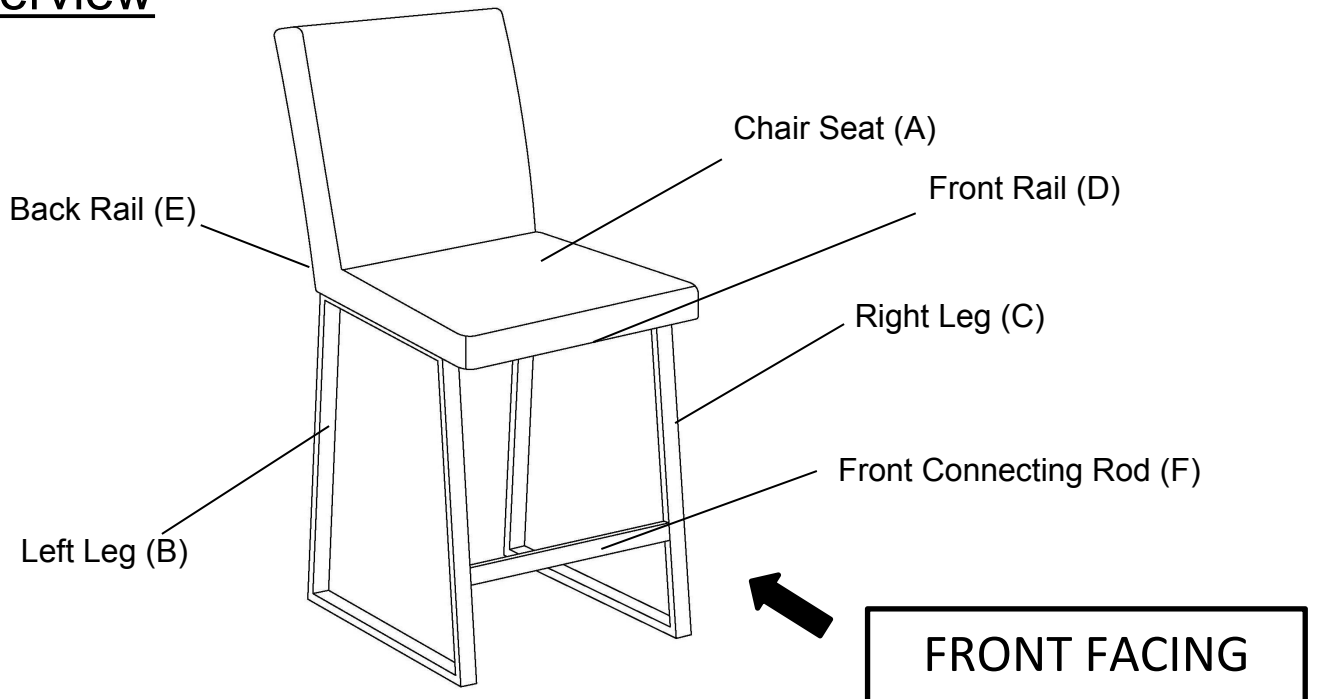

This Barstool has multiple parts and may require up to 30 minutes to assemble. To give you an overview of the Barstool, the above picture is to help you put the various parts into perspective. Please read through the instructions below to familiarise yourself with the parts and steps before assembly.

Step 1

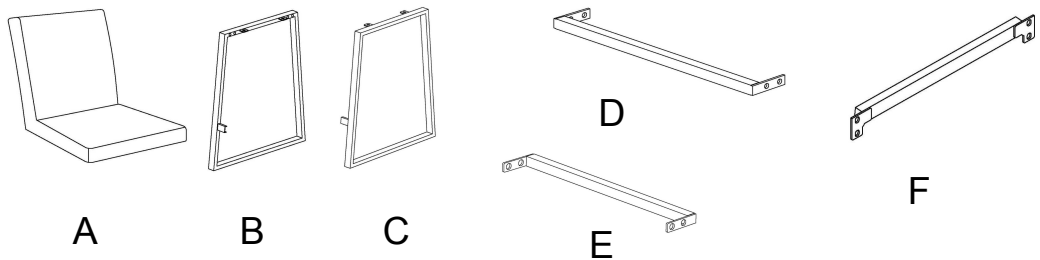

Place the Chair Seat (A), Left Leg (B), Right Leg (C), Front Rail (D), Back Rail (E) and Front Connecting Rod (F) onto a clean, non-marring surface.

Step 2

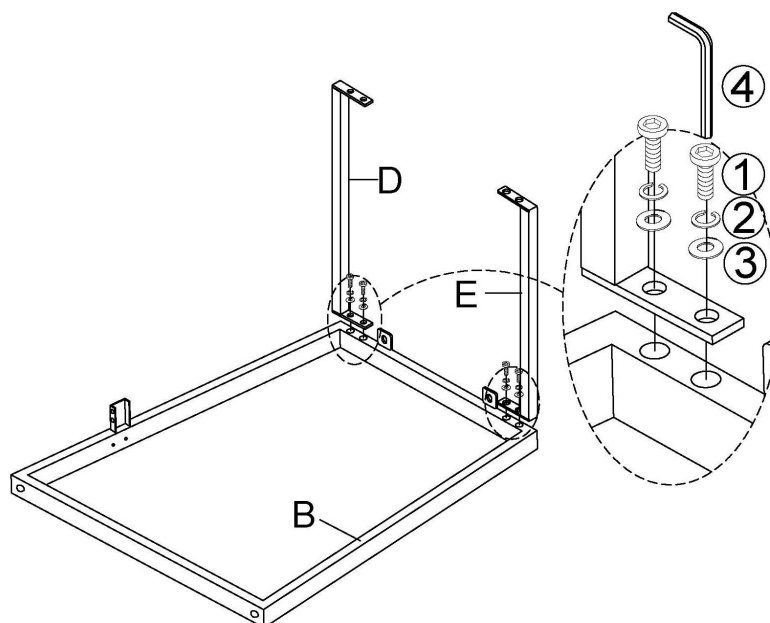

Attach Front Rail(D) and Back Rail(E) to Left Leg(B) using Bolts(①), Spring Washer(②) and Washer(③) with Allen Wrench(④) as shown above. Please note: This Step do not fully tighten the Bolts.

Step 3

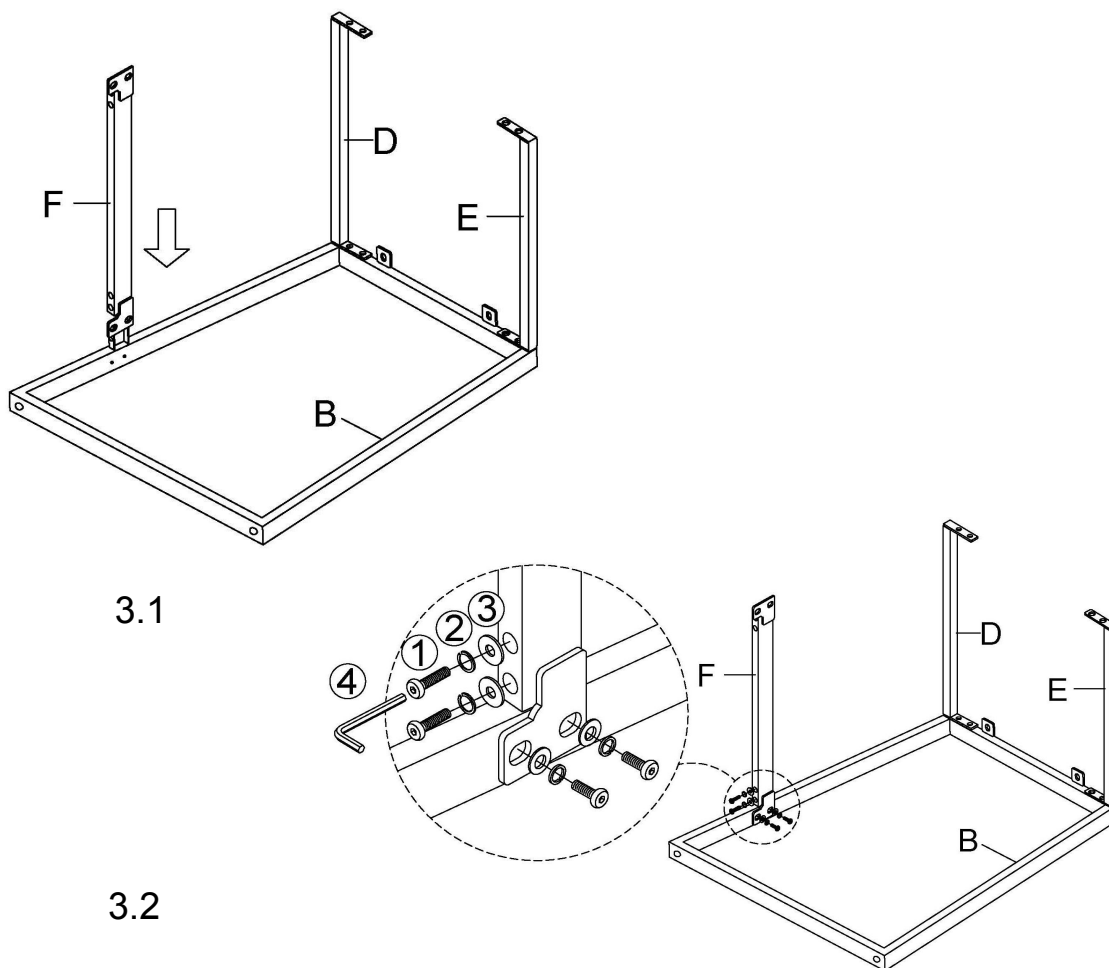

3.1) Insert Front Connecting Rod(F) into Left Leg(B) as shown above.
3.2) Attach Front Connecting Rod(F) to Left Leg(B) using Bolts(①), Spring Washer(②) and Washer(③) with Allen Wrench(④) as shown above.
Please note: This Step do not fully tighten the Bolts.

Step 4

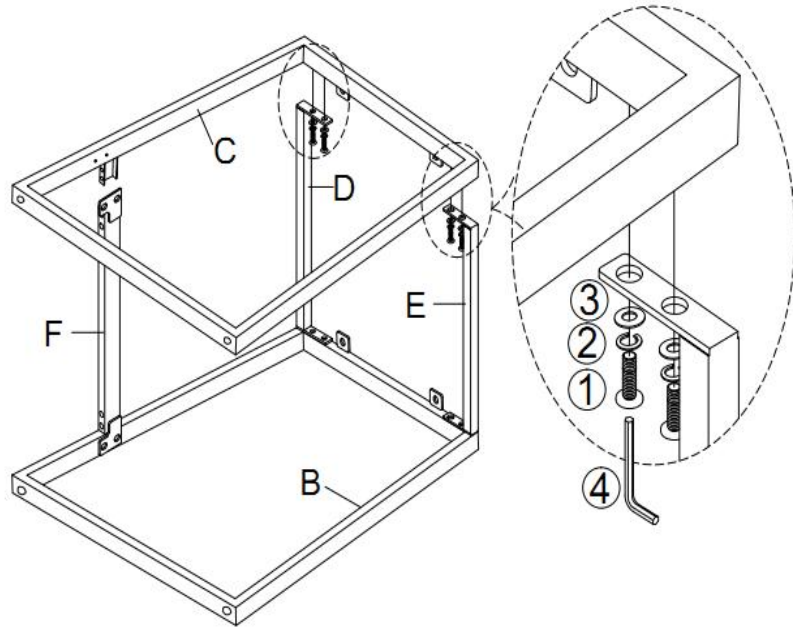

Align Right Leg(C) to Front Rail(D), Back Rail(E) and Front Connecting Rod(F) using Bolts(①), Spring Washer(②) and Washer(③) with Allen Wrench(④) as shown above.
Please note: This Step do not fully tighten the Bolts.

Step 5

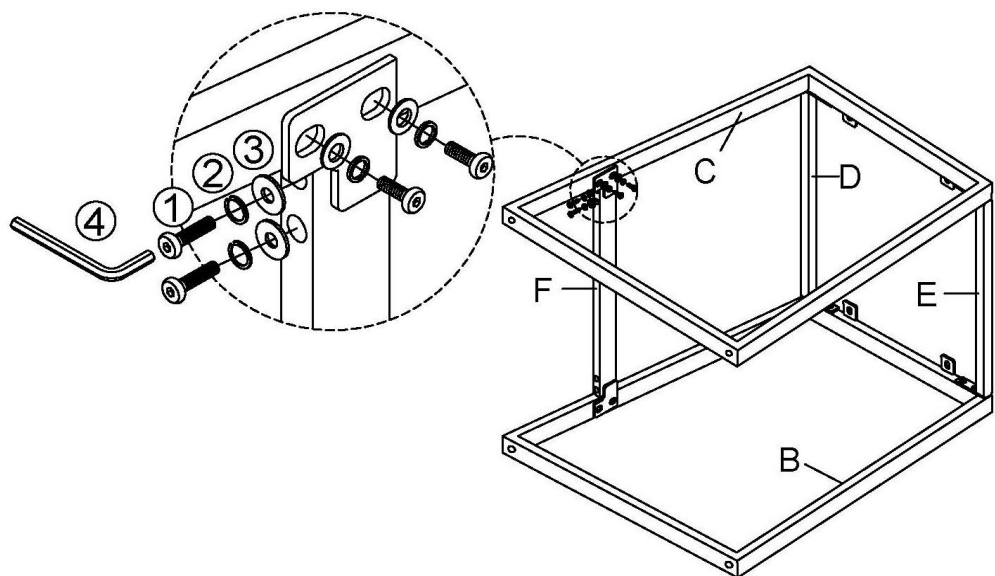

Insert Right Leg(C) into Front Connecting Rod(F) using Bolts(①), Spring Washer(②) and Washer(③) with Allen Wrench(④) as shown above.
Please note: This Step do not fully tighten the Bolts.

Step 6

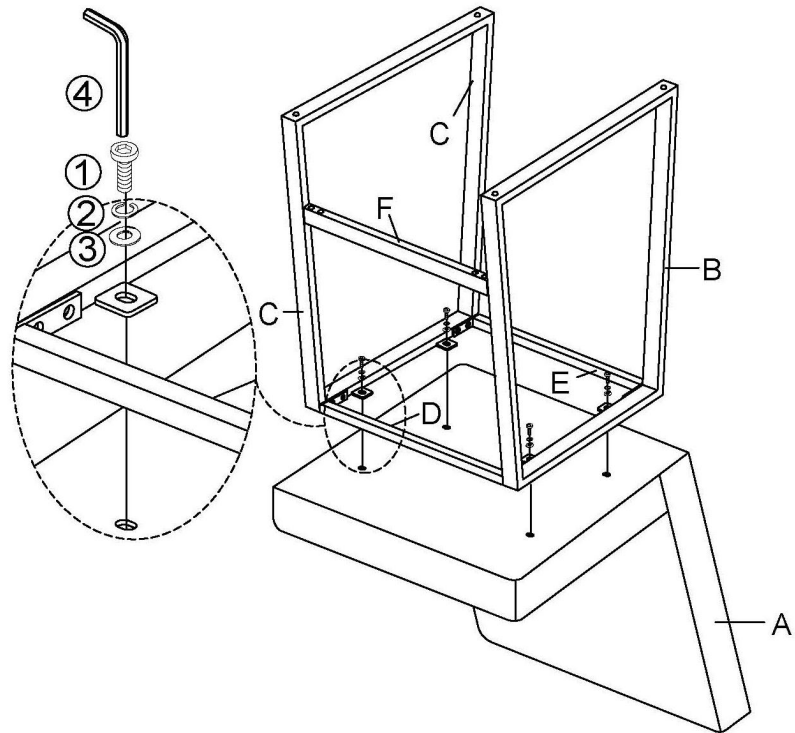

Align Left Leg(B) and Right Leg(C) to the bottom of Chair Seat(A) and attach using Bolts(①), Spring Washer(②) and Washer(③) with Allen Wrench(④) as shown above.

Tighten all Bolts at all joints fully in a sequential manner.

Step 7

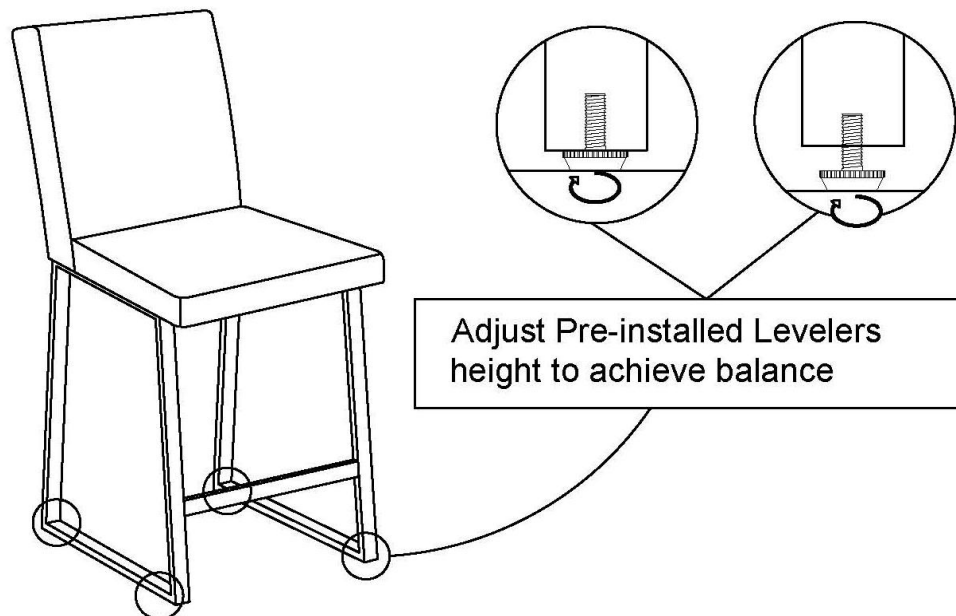

Adjust the Pre-installed Levelers at the bottom of Left Leg (B) and Right Leg (C) until the Barstool is level with the ground.



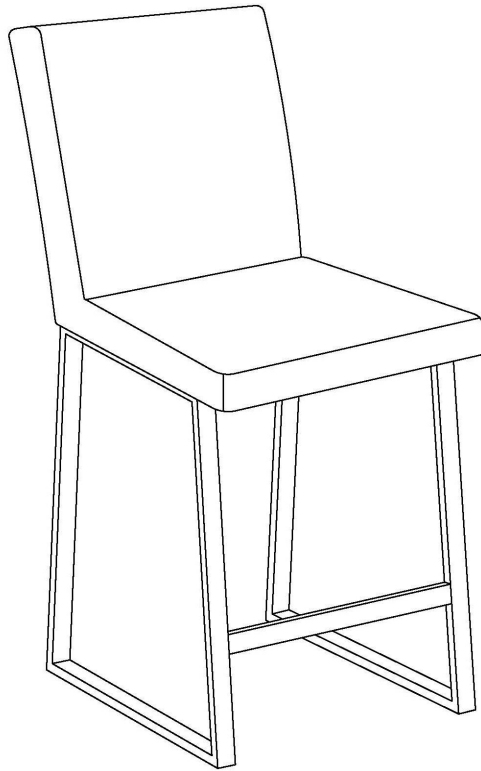







Step 8



Your Barstool is ready for use.

This Barstool can only be used on a flat, level surface.

Care & Maintenance

- ⊘  ● Not for commercial use. For residential use only.
 - ✓  ● Furniture may scratch floors. We recommend using furniture pads to protect your floors.
 - ⊘  ● Do not put hot items directly on furniture surface.
 - ⊘  ● Do not clean furniture with harsh cleansers or polish.
 - ⊘  ● Do not place furniture under direct sunlight.
 - ⊘  ● Do not place furniture near heating or cooling vents.
 - ⊘  ● Do not write on furniture without a padded barrier to protect the surface.
 - ⊘  ● Do not place furniture outside . For indoor use only.
 - ⊘  ● Stains may be removed with mild soap solution and damp cloth.
 - ⊘  ● Children should not climb or jump on the furniture.
-
- ✓  ● Dust and pick-up spills using a clean, non-colored, lint-free cloth.