

ASSEMBLY INSTRUCTION FOR C220054D P1

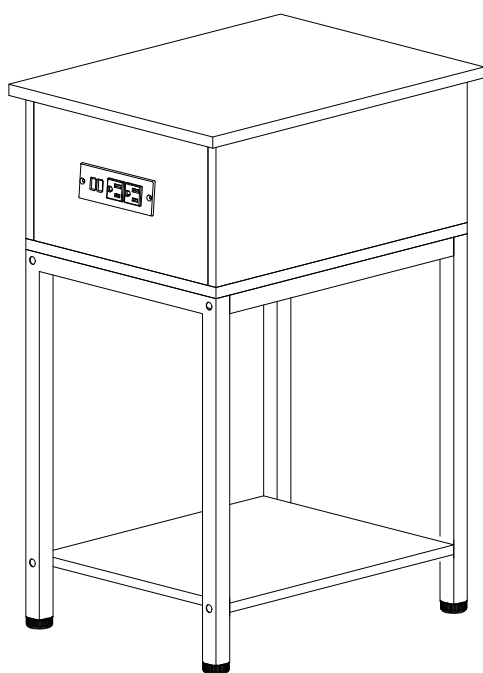

1

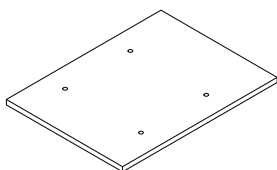

2

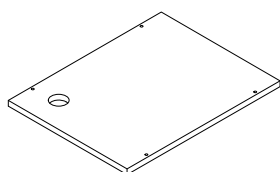

3

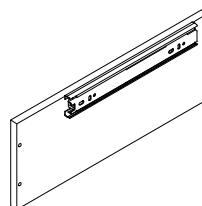

4

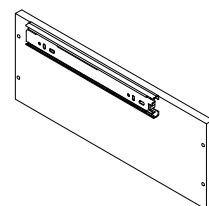

5

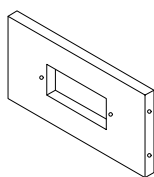

6

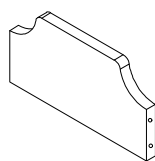

7

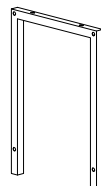

2PCS

8



2PCS

9

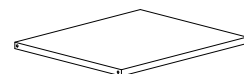

A



M6X35
4PCS

B



M6X28
4PCS

C



M5X50
4PCS

D

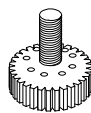

M8

E



M3.5X12
6PCS

F



M4X8
4PCS

G



M4
4PCS

H

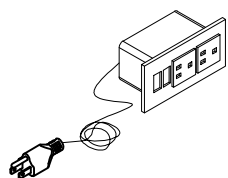

I



M6X50
4PCS

J

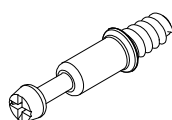

M6.3X35
8PCS

K

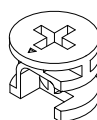

Ø15X9.5
8PCS

L

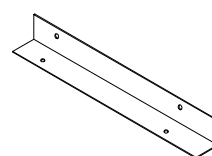

2PCS



ASSEMBLY INSTRUCTION FOR C220054D P2

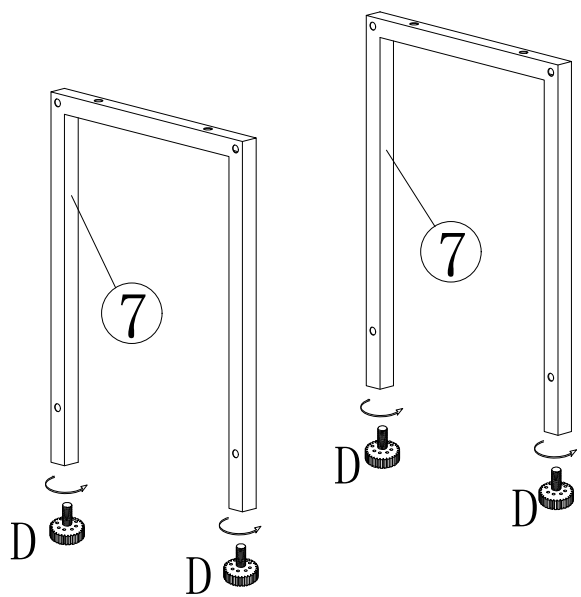
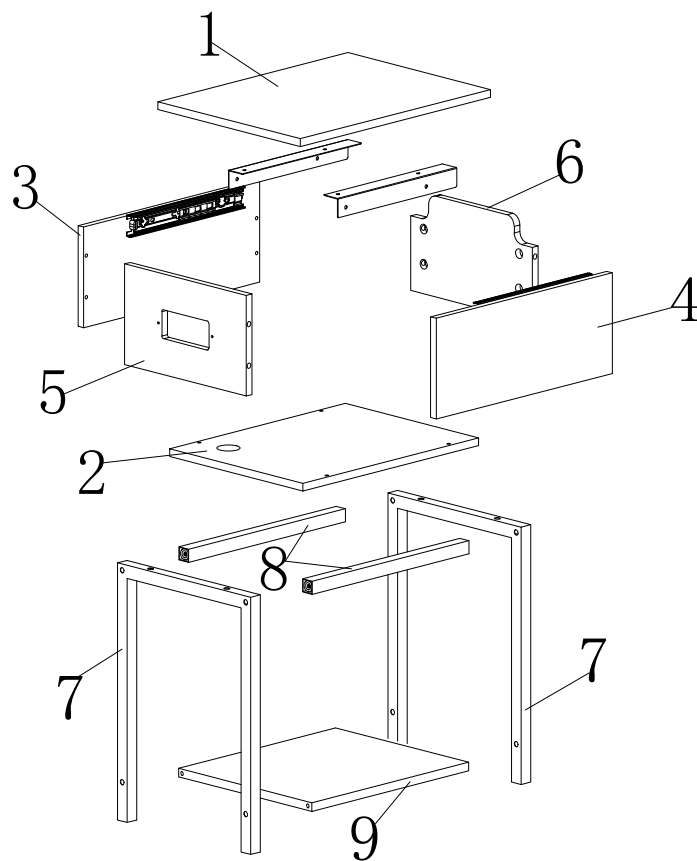

D X4

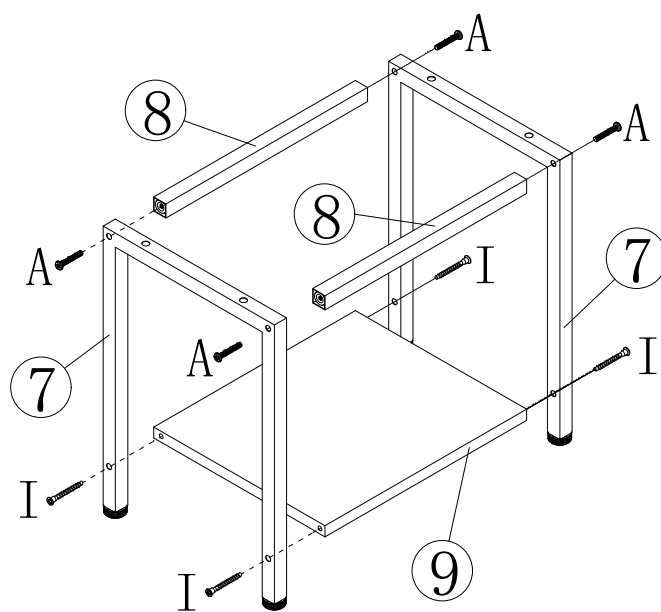

A M6X35X4pcs

I M6X50X4pcs

ASSEMBLY INSTRUCTION FOR C220054D P3

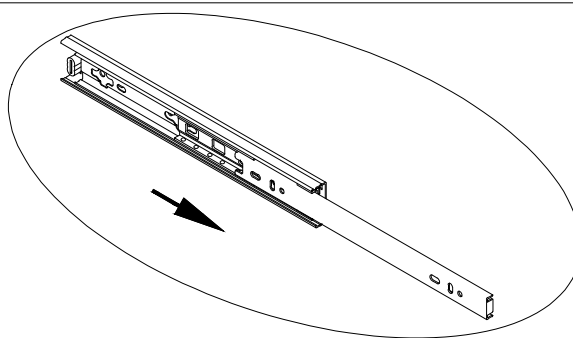
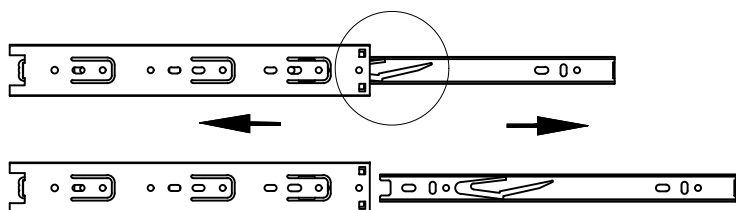
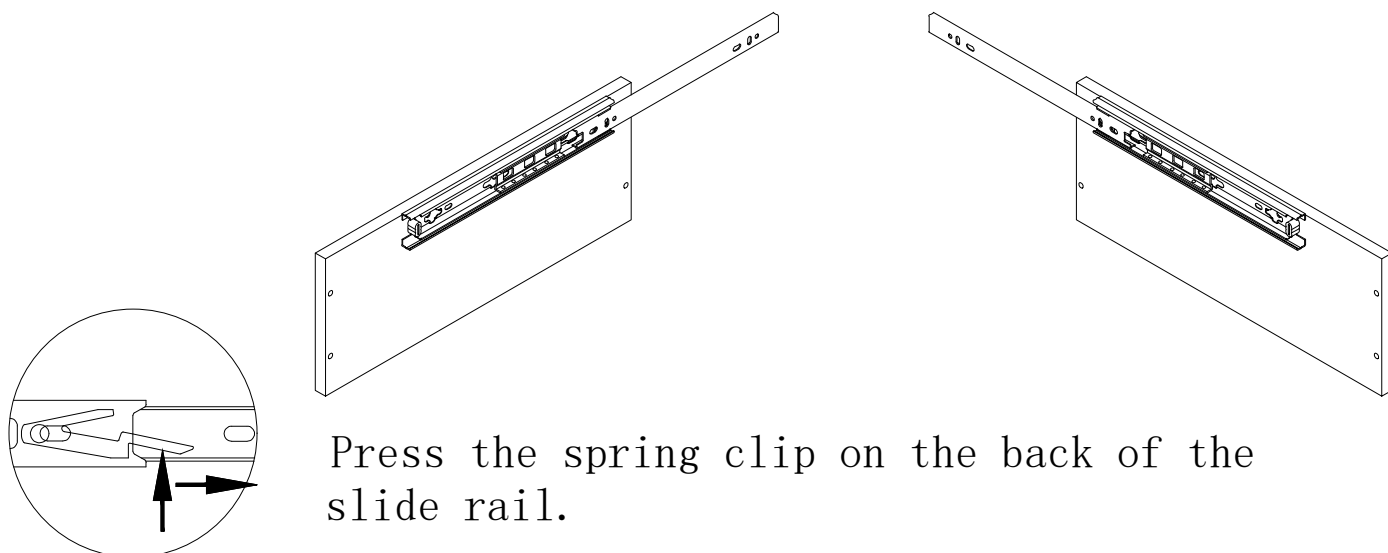

Remove the inner rail from the main body of the slide rail. Leave the inner rail for the next step.

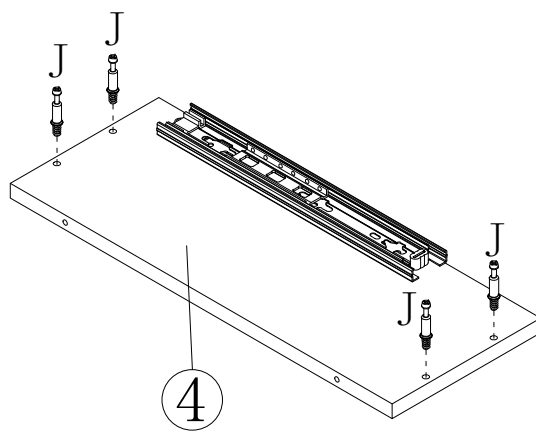
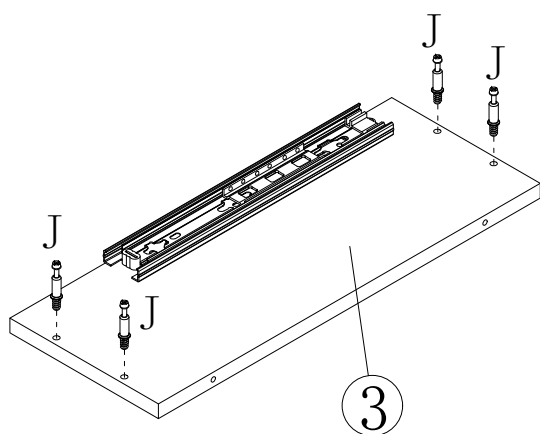

J M6.3X35X8pcs

ASSEMBLY INSTRUCTION FOR C220054D P4

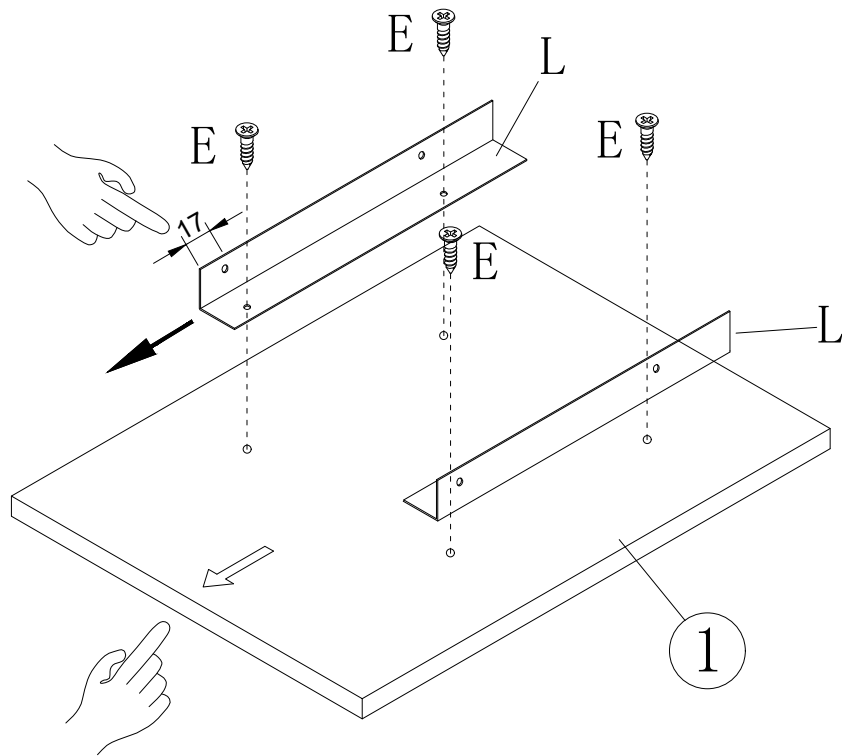

E M3.5X4PCS

F M4X8X4PCS
G M4X4PCS

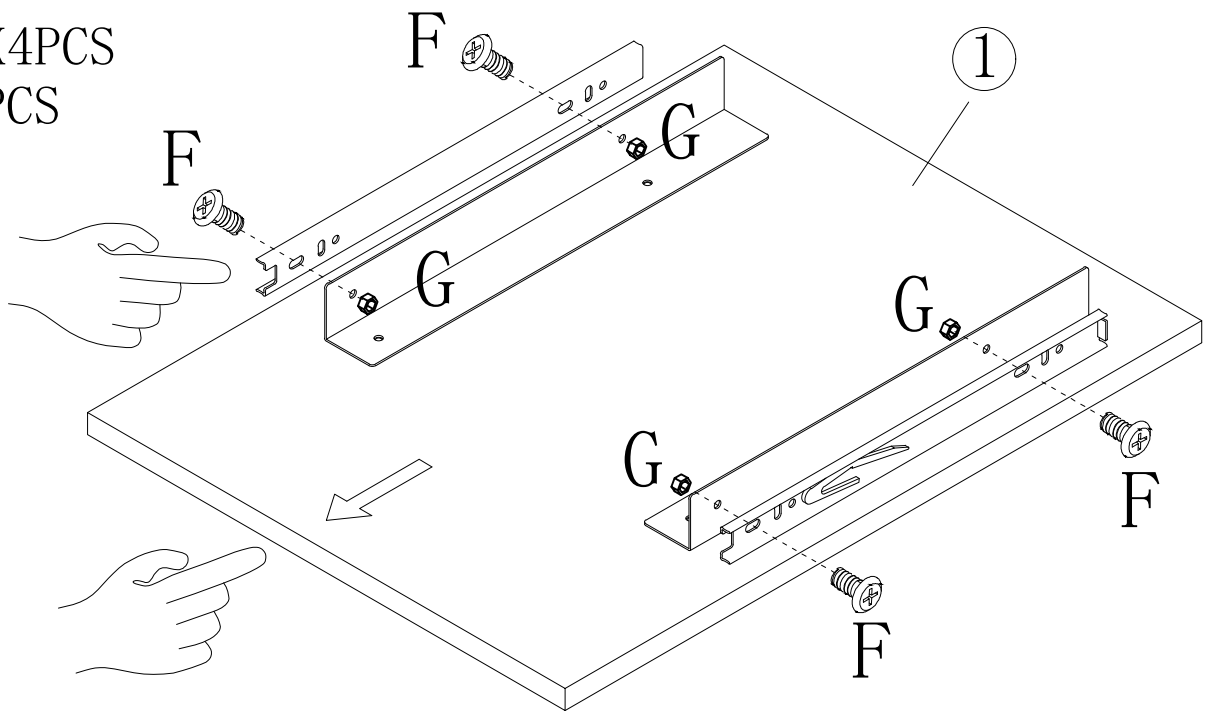

Use part F and part G to lock the inner rail. Make sure the part F is on the outside and lock the Horizontal Oval Hole on the inner rail.

ASSEMBLY INSTRUCTION FOR C220054D P5

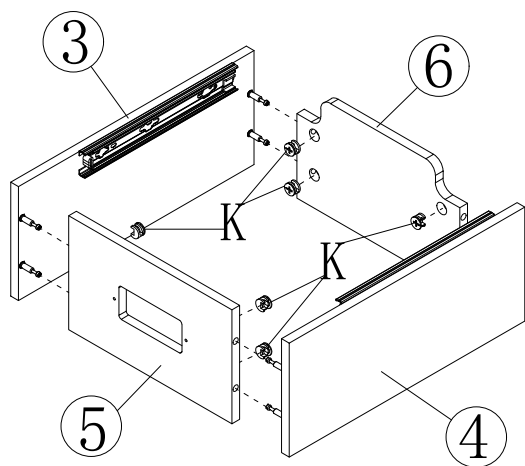

K $\text{Ø}15 \times 9.5 \times 8$ pcs

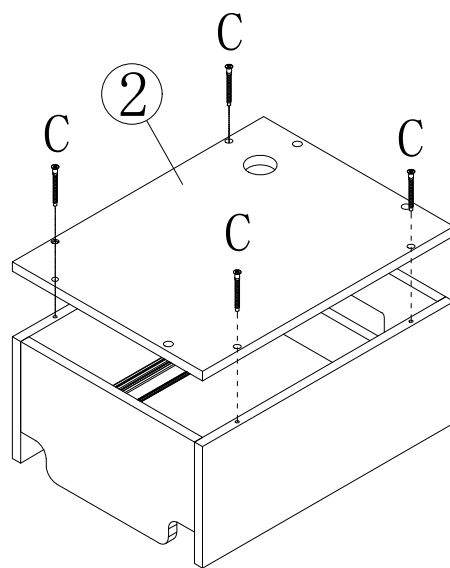

C M5X50X4 pcs

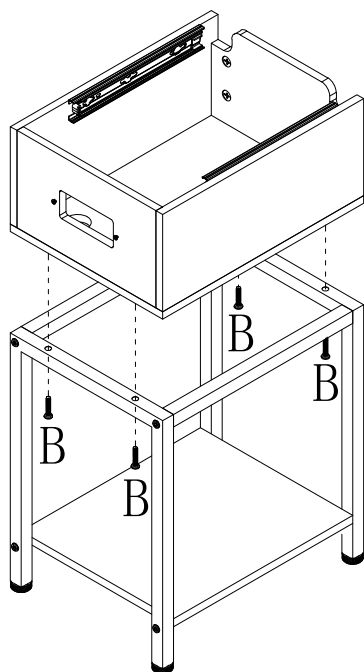

B M6X28X4 pcs

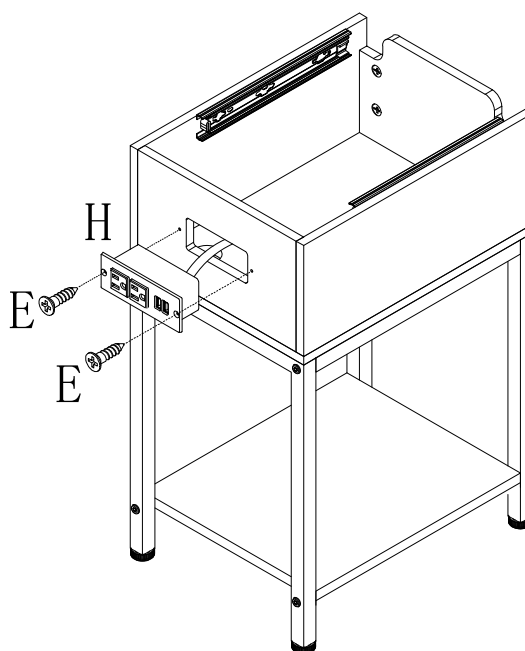

E M4X2PCS

ASSEMBLY INSTRUCTION FOR C220054D P6

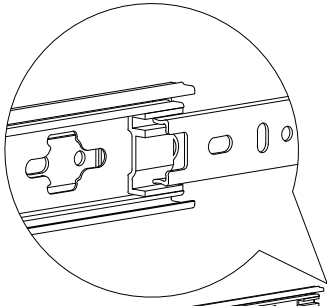

locking the middle
fixing rail in order
to move in

