

DGSJ-V1

FTOFWF-0002
FTOFWF-0003

CONTACT US:

If you have any questions about the installation of YITAHOME products, just e-mail us at after-sale .cs@hotmail . com .
Alternative method to contact us (amazon.co.uk orders only)

1. Log into your Amazon account
2. Go to " Your Orders " and find the purchase
3. Click on " Contact Seller "

EN
KONTAKTIEREN UNS :

Wenn Sie Fragen zur Installation von YITAHOME-Produkten haben, senden Sie bitte einfach eine E-Mail an after-sale.cs@hotmail.com.

Alternative Methode, um uns zu kontaktieren (nur bei amazon.co.uk)

- 1.Melden Sie sich in Ihrem Amazon-Konto an
2. Gehen Sie zu "Ihre Bestellungen" und finden Sie den Kauf
3. Klicken Sie auf "Verkäufer kontaktieren"

DE
CONTACTEZ-NOUS:

Si vous avez des questions concernant l'installation des produits YITAHOME, il vous suffit de envoyer un e-mail à after-sale.cs@hotmail.com

Autre méthode pour nous contacter (commandes sur amazon.co.uk uniquement)

- 1.Connectez-vous à votre compte Amazon
- 2.Allez dans "Vos commandes" et trouvez l'achat
3. Cliquez sur "Contacter le vendeur"

FR
CONTATTACI:

In caso di domande sull'installazione dei prodotti YITAHOME, inviare un'e-mail a after-sale.cs@hotmail.com.

Metodo alternativo per contattarci (solo ordini amazon.co.uk)

- 1.Accedi al tuo account Amazon
2. Vai a "I tuoi ordini" e trova l'acquisto
- 3.Fai clic su "Contatta il venditore"

IT
CONTÁCTENOS:

Si tiene alguna pregunta sobre la instalación de los productos YITAHOME, envíenos un correo electrónico a after-sale.cs@hotmail.com.

Método alternativo para contactarnos (solo pedidos de amazon.co.uk)

- 1.Inicie sesión en su cuenta de Amazon
2. Vaya a "Sus pedidos" y busque la compra
3. Haga clic en "Contactar al vendedor"

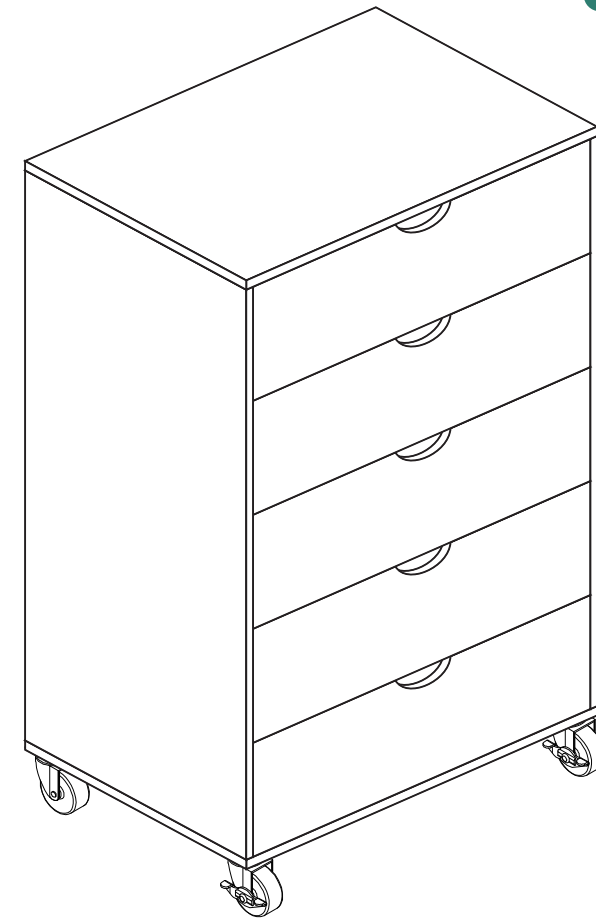
ES

MOBILE 5-DRAWER FILING CABINET
MOBILER AKTENSCHRANK MIT 5 SCHUBLADEN
CLASSEUR MOBILE À 5 TIROIRS
SCHEDARIO MOBILE A 5 CASSETTI
ARCHIVADOR MÓVIL DE 5 CAJONES

Notice:

1. Follow the installation instructions. Please confirm all accessories are preset before installation.
2. Do not fully tighten the screws during initial assembly. Fully tighten screws only once all pieces which are correctly assembled.
3. If you encounter any problems during installation, refer to two solutions: Follow the installation video tutorial on the Amazon product page or contact our customer service.

Beachten:

1. Befolgen Sie die Installationsanweisungen. Bitte bestätigen Sie vor der Installation, dass alle Zubehörteile voreingestellt sind.
2. Ziehen Sie die Schrauben bei der Erstmontage nicht vollständig an. Stellen Sie das Board vorsichtig so ein, dass es eben ist. Erst festziehen, wenn alle Teile richtig zusammengesetzt sind.
3. Wenn während der Installation Probleme auftreten, finden Sie zwei Lösungen: Befolgen Sie das Installationsvideo-Tutorial auf der Amazon-Produktseite oder wenden Sie sich an unseren Kundendienst.

Remarques:



1. Suivez les instructions d'installation. Assurez-vous que toutes les pièces jointes sont prépositionnées avant l'installation svp.
2. Ne serrez pas complètement les vis lors de l'installation initiale. Ajustez doucement les plaques pour les niveler. Serrez seulement après que tous les composants ont été assemblés correctement.
3. Si vous rencontrez des problèmes lors de l'installation, référez-vous à deux solutions: suivez le didacticiel vidéo d'installation sur la page de produit Amazon ou contactez notre service à la clientèle.

Nota:

1. Seguire le istruzioni di installazione. Assicurarsi che tutti gli accessori siano preresolati prima dell'installazione.
2. Non avvitare completamente le viti durante l'assemblaggio iniziale. Regolare delicatamente le assi per livellarle. Avvitare solo quando tutti i pezzi sono assemblati correttamente.
3. Se incontri qualsiasi problema durante l'installazione, fai riferimento a queste due soluzioni: Segui il video tutorial d'installazione sulla pagina Amazon del prodotto o contatta il nostro servizio clienti.

Aviso:

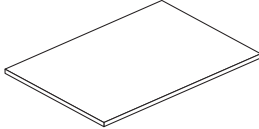
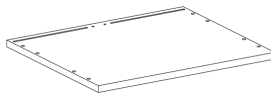
1. Siga las instrucciones de instalación. Revise que todos los accesorios estén en condiciones antes de la instalación.
2. No apriete los tornillos por completo durante la instalación inicial. Ajuste suavemente el tablero para nivelar. Apriete por completo una vez que todas las piezas estén colocadas correctamente.
3. Si encuentra algún problema durante la instalación: siga el video tutorial de instalación en la página del producto en Amazon, o póngase en contacto con nuestro servicio de atención al cliente.

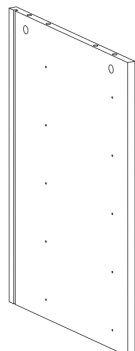
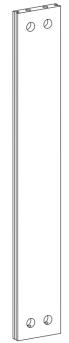
Item no. Nr. N° d'article Articolo No. Artículo No.	Reference Image Referenzbild Image de référence Immagine di riferimento Imagen de referencia	Qty. Menge Qté. Qtà Cant.	Item no. Nr. N° d'article Articolo No. Artículo No.	Reference Image Referenzbild Image de référence Immagine di riferimento Imagen de referencia	Qty. Menge Qté. Qtà Cant.
A		X 1	D		X 1
B		X 1	E		X 2
C		X 1	F		X 1

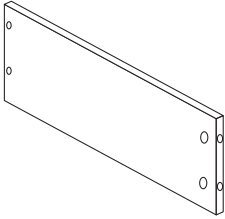
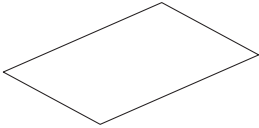
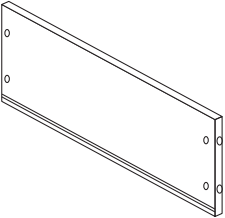
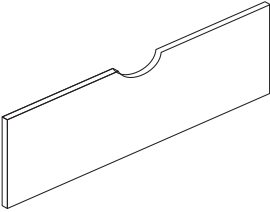
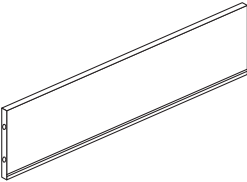
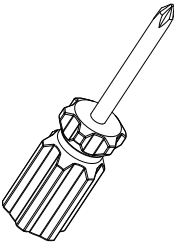
Item no. Nr. N° d'article Articolo No.	Reference Image Referenzbild Image de référence Immagine di riferimento Imagen de referencia	Qty. Menge Qté. Qtà Cant.	Item no. Nr. N° d'article Articolo No.	Reference Image Referenzbild Image de référence Immagine di riferimento Imagen de referencia	Qty. Menge Qté. Qtà Cant.
G		X 5	J		X 5
H		X 5	K		X 5
I		X 5	L		X 1

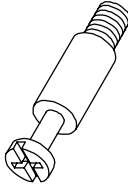
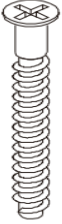
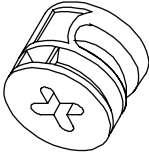
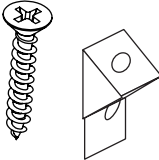
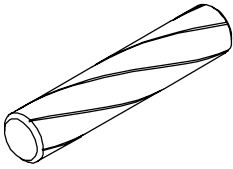
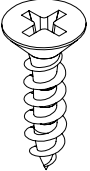
Item no. Nr. N° d'article Articolo No.	Reference Image Referenzbild Image de référence Immagine di riferimento Imagen de referencia	Qty. Menge Qté. Qtà Cant.	Item no. Nr. N° d'article Articolo No.	Reference Image Referenzbild Image de référence Immagine di riferimento Imagen de referencia	Qty. Menge Qté. Qtà Cant.
a	 M5*35mm	x28	d	 M5*38mm	x20
b	 M15*9.5mm	x28	e	 M3*16mm	x12
c	 M8*30mm	x8	f	 M3.5*14mm	x56

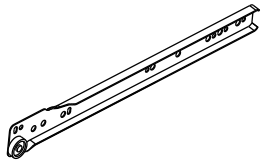
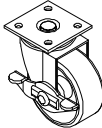
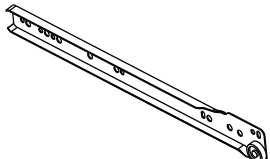
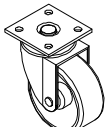
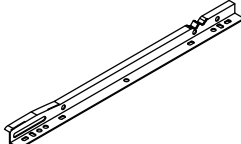
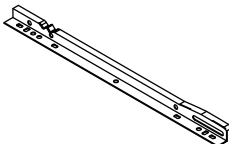
Item no. Nr. N° d'article Articolo No. Artículo No.	Reference Image Referenzbild Image de référence Immagine di riferimento Imagen de referencia	Qty. Menge Qté. Qtà Cant.	Item no. Nr. N° d'article Articolo No. Artículo No.	Reference Image Referenzbild Image de référence Immagine di riferimento Imagen de referencia	Qty. Menge Qté. Qtà Cant.
g	 M6*38mm	x4	CL		X 5
h		X 2	CR		X 5
i		X 2	DL		X 5
			DR		X 5

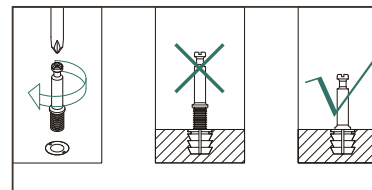

Tighten@clockwise until all of their threads are engaged.

Ziehen Sie die@im Uhrzeigersinn an, bis alle Gewingänge eingerastet sind

Serrez les@dans le sens des aiguilles d'une montre jusqu'à ce que tous leurs filets soient engagés.

Serrare@in senso orario fino a quando tutte le filettature sono impegnate.

Apriete@en el sentido de las agujas del reloj hasta que todas sus roscas estén engranadas.

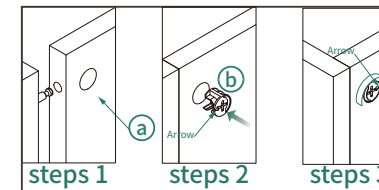

Step 1/2/3
Arrow

The two plates fit vertically, place ⓑ and match their holes with ⓐ, then tighten ⓑ clockwise.

Stufe 1/2/3
Pfeil

Die beiden Platten passen senkrecht aufeinander, legen ⓑ und ihre Löcher mit ⓐ übereinstimmen, dann ⓑ im Uhrzeigersinn anziehen.

Étape 1/2/3
Flèche

Les deux plaques s'emboîtent verticalement, placez ⓑ et faire correspondre leurs trous avec ⓐ, puis serrer ⓑ dans le sens des aiguilles d'une montre.

Passo 1/2/3
Freccia

Le due piastre si incastrano verticalmente, posizionando ⓑ e far coincidere i fori con ⓐ, quindi serrare ⓑ in senso orario.

Paso 1/2/3
Flecha

Las dos placas encajan verticalmente, coloque ⓑ y hacer coincidir sus orificios con los de la ⓐ, y luego apretar ⓑ en el

1

X5

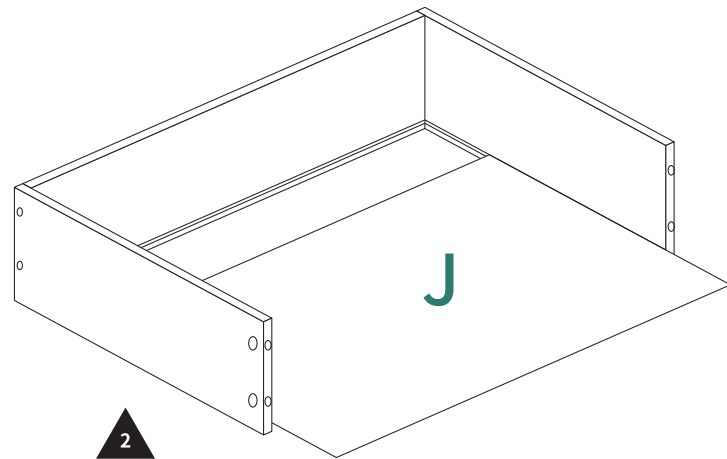
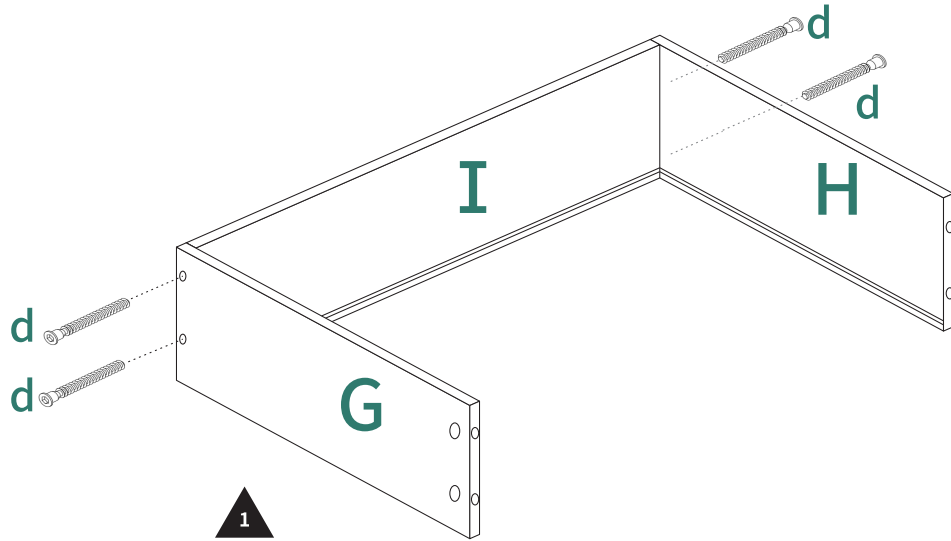
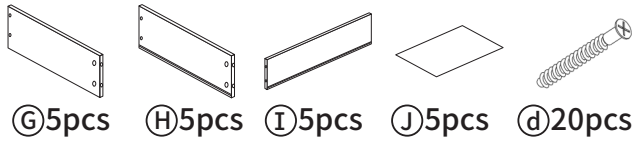

7

2

X5

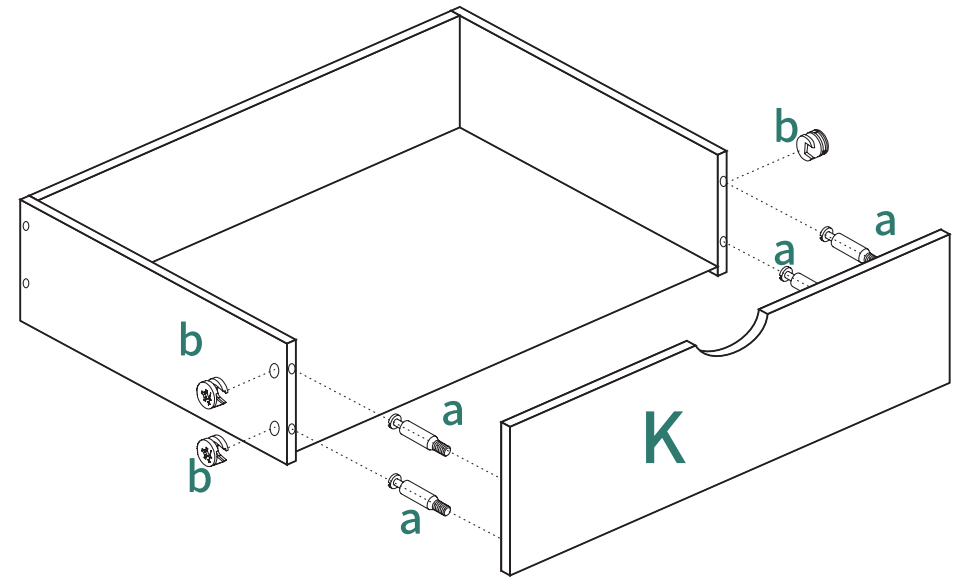

8

3
X5
DR 5pcs DL 5pcs f 20PCS

4
B 1pc C 1pc CR 5pcs CL 5pcs f 20PCS

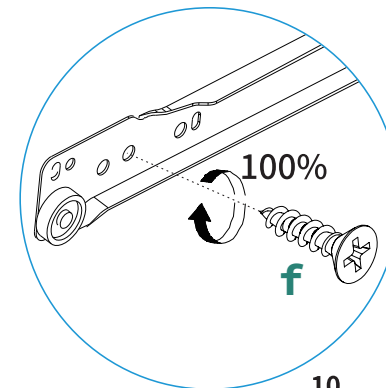
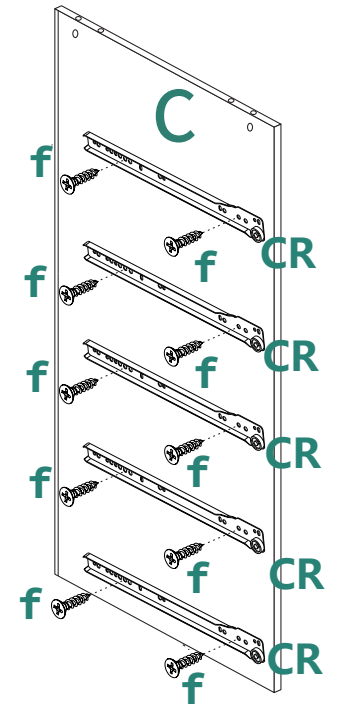
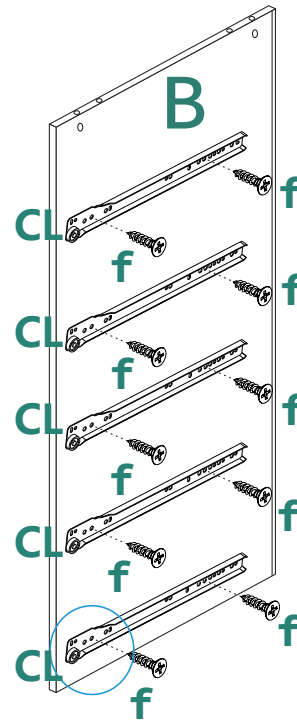
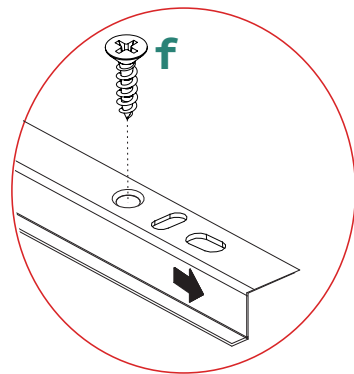
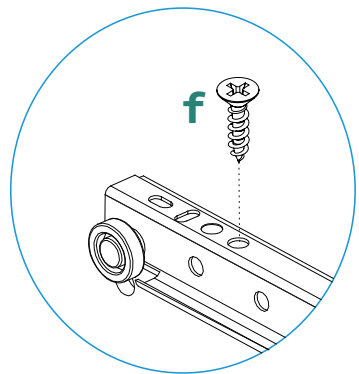
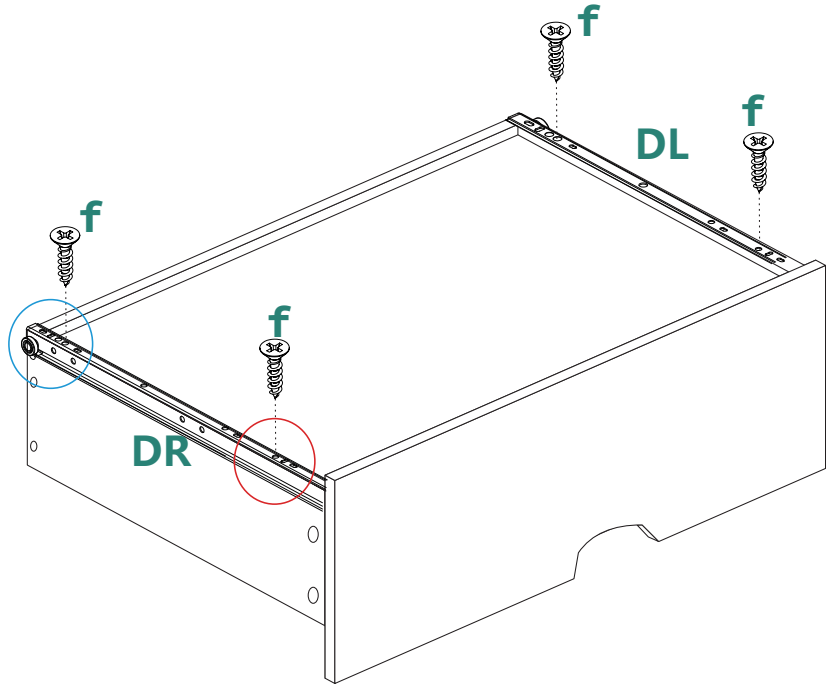

5

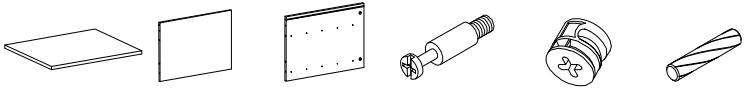

A1PCS **B**1PCS **C**1PCS **a**4PCS **b**4PCS **c**4PCS

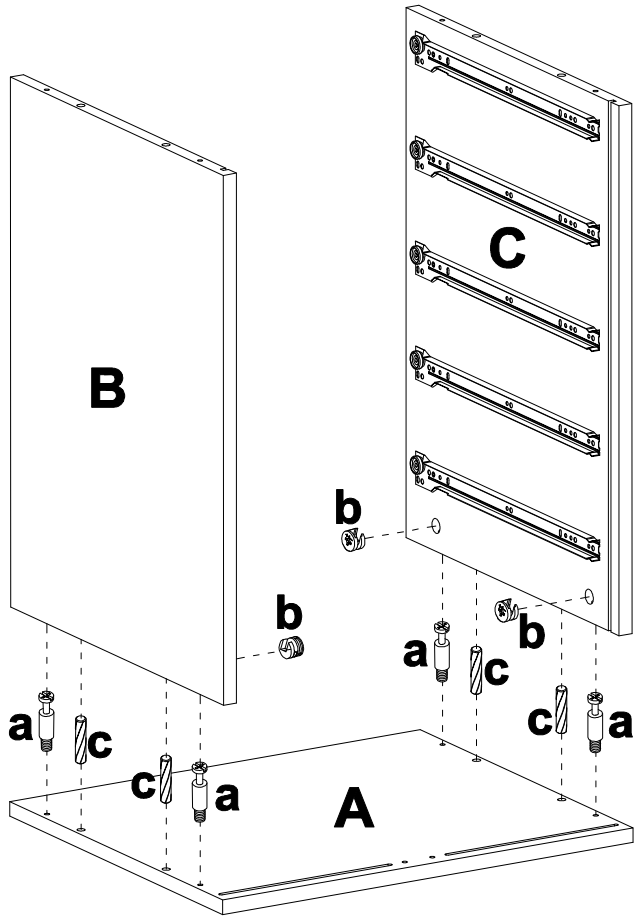

6

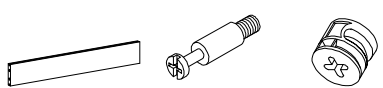

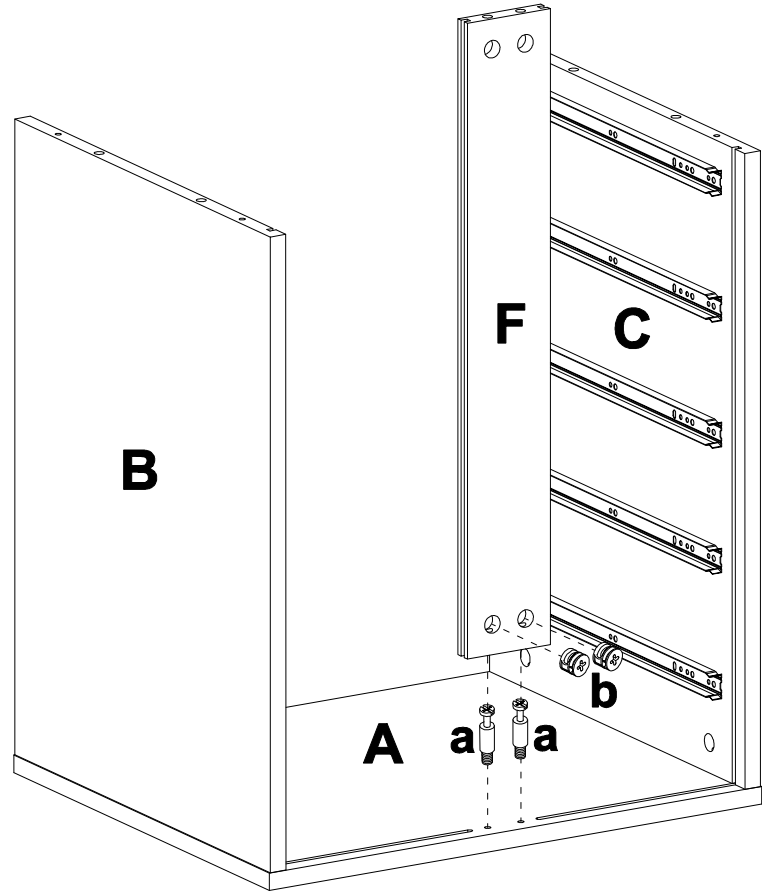

F1PCS **a**2PCS **b**2PCS

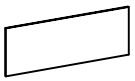

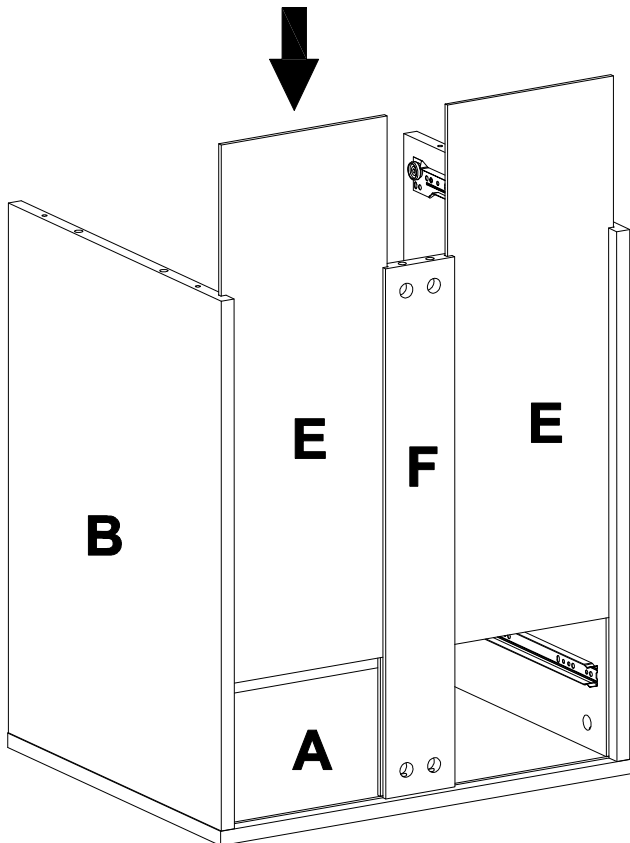

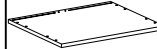

7  **E1PCS**

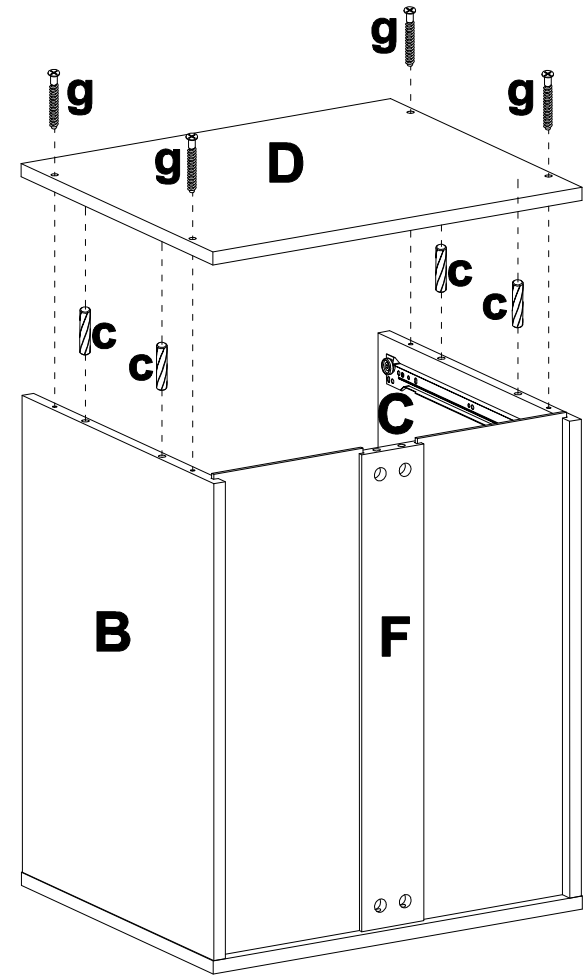

8  **D1PCS**  **C4PCS**  **g4PCS**



9   
f 16PCS h 2PCS i 2PCS

10  
e 12PCS

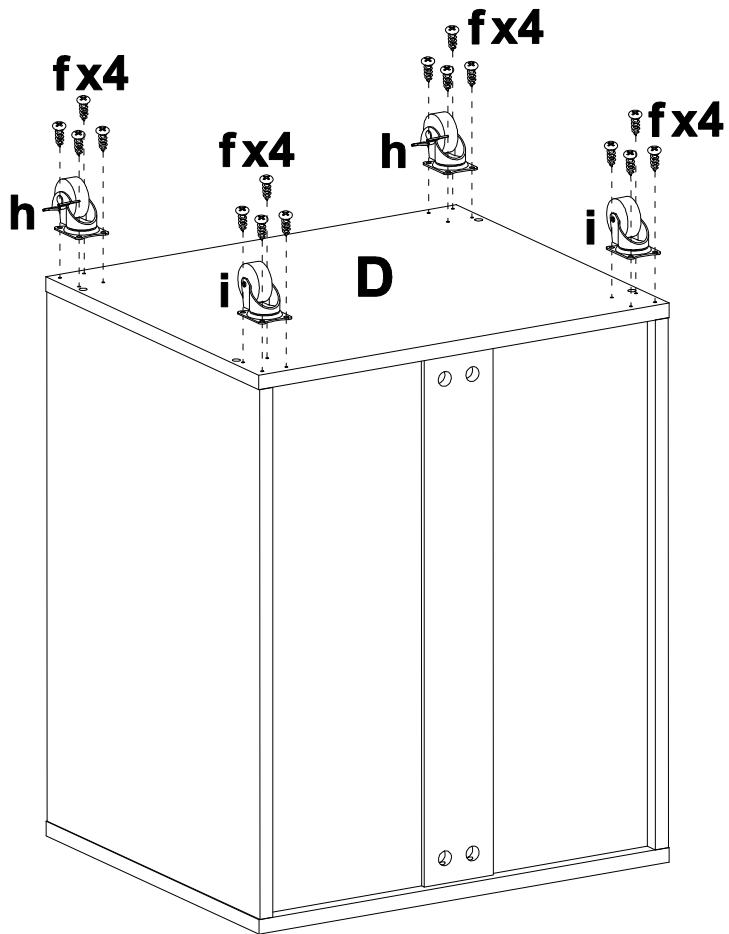

15

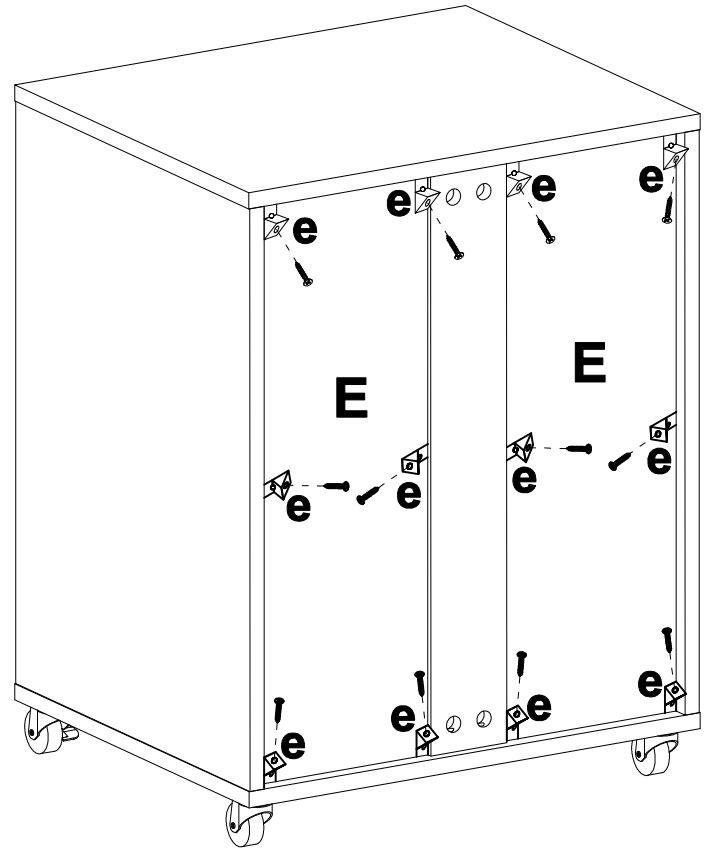

16

11

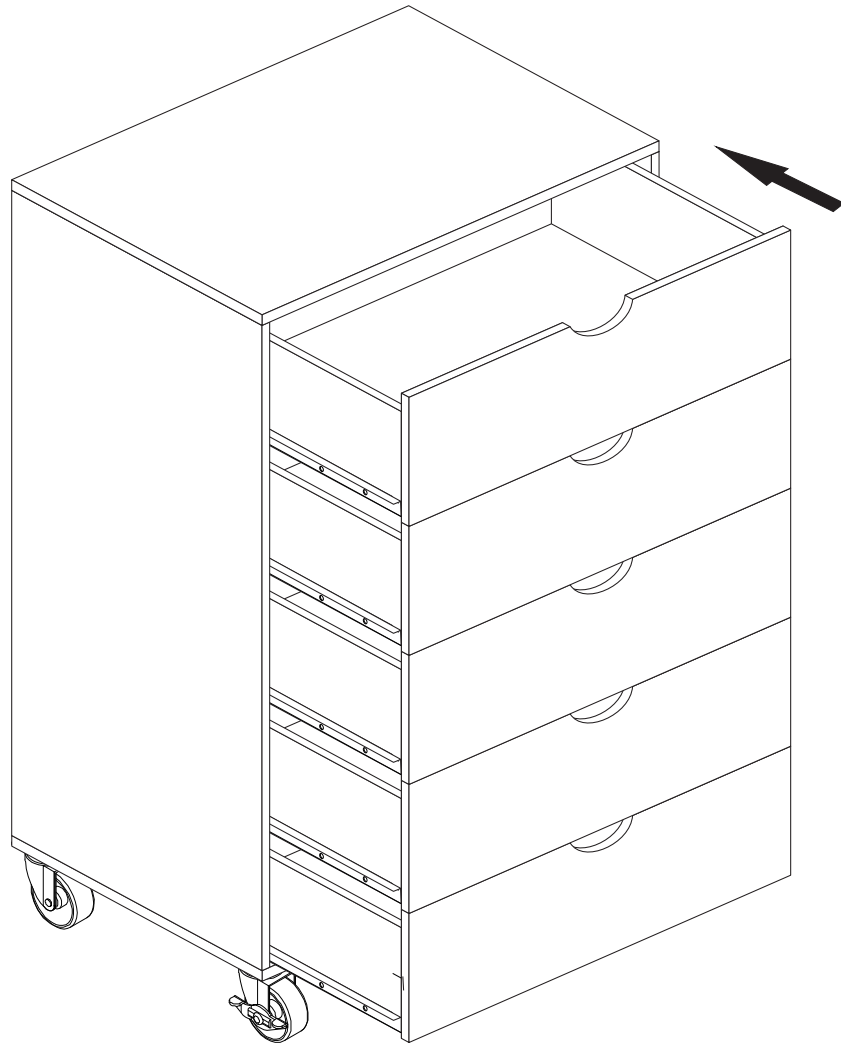

17

12



Installation Completed

Installation Abgeschlossen

Installation Complète

Installazione Completata

Instalación Completa

18