

Coffee Table

Perfectly designed with simplicity in mind

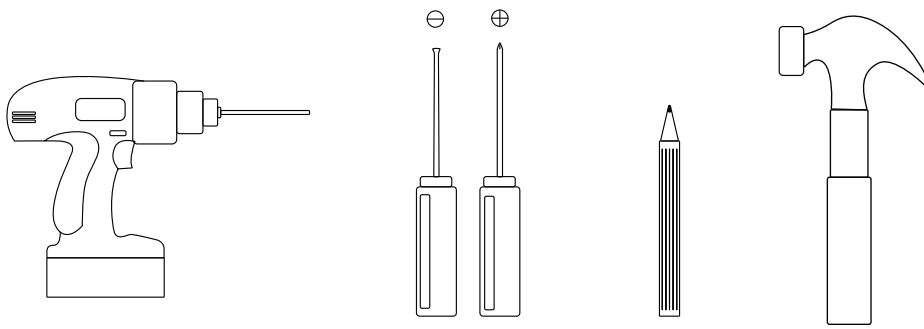

If you have these tools at home to assist you, assembly will be quicker.
If not, no worries, we have included everything required for assembly in the package.

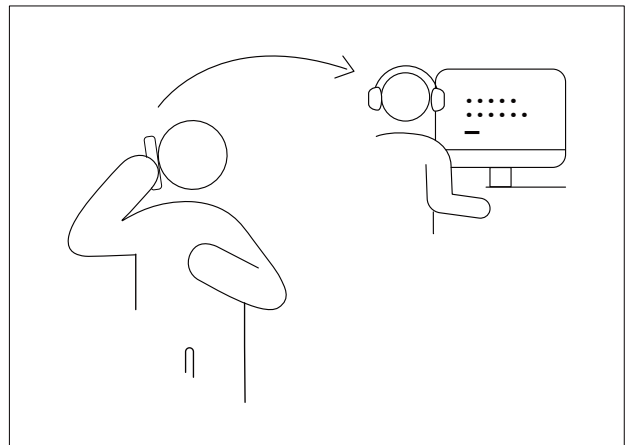
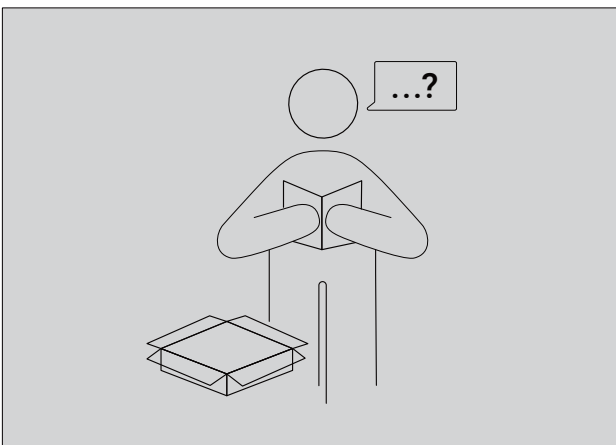
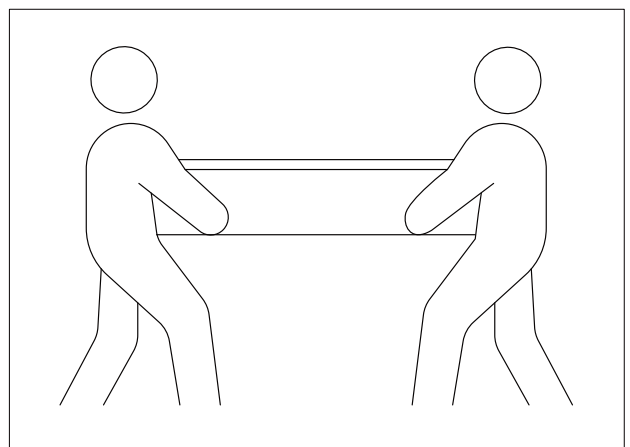
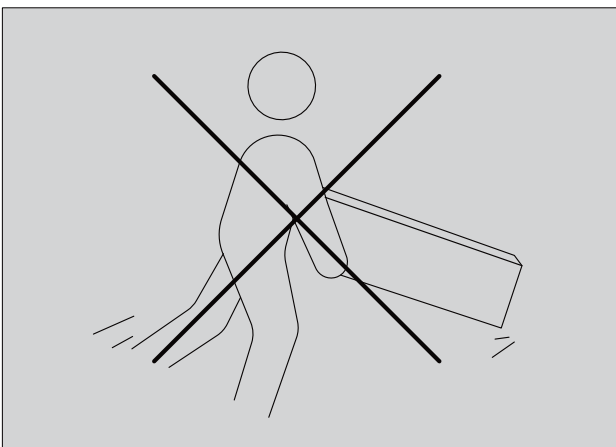
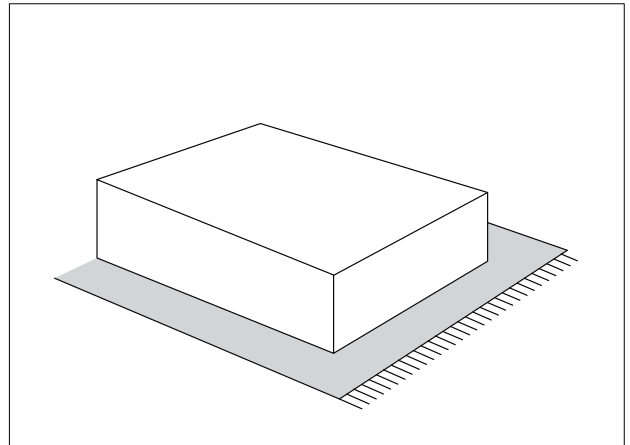
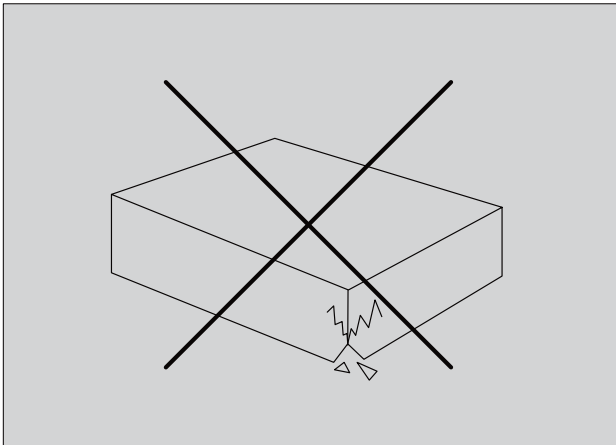

PARTS

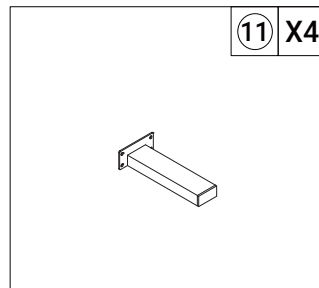
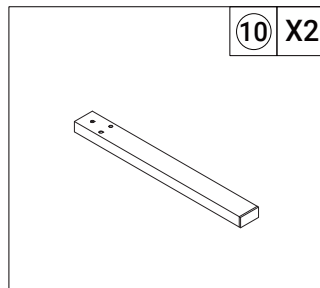
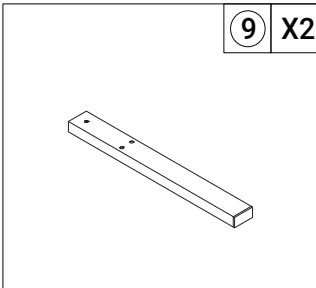
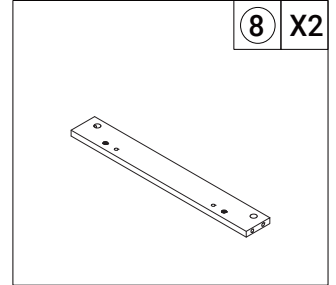
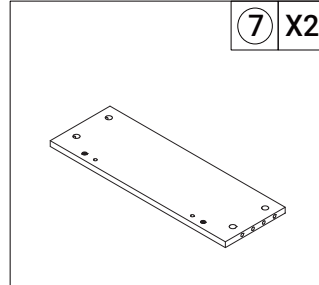
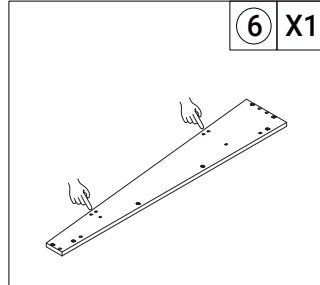
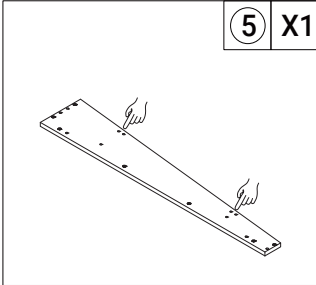
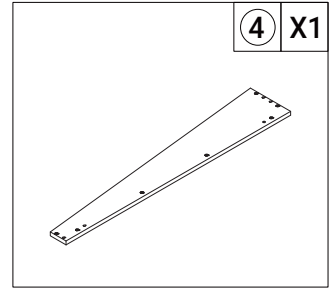
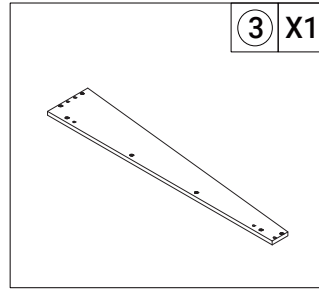
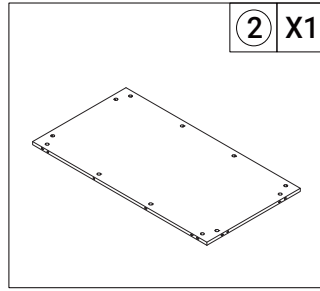
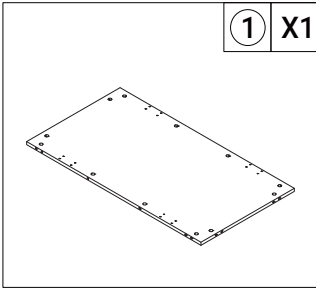

HARDWARE

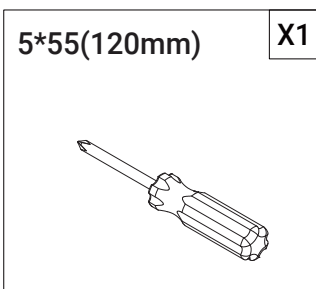
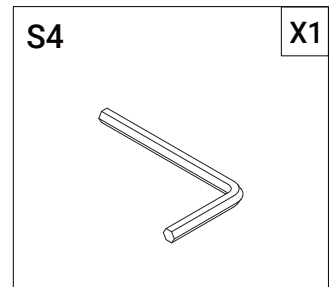
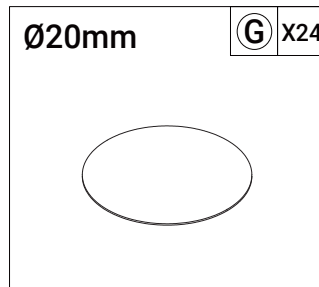
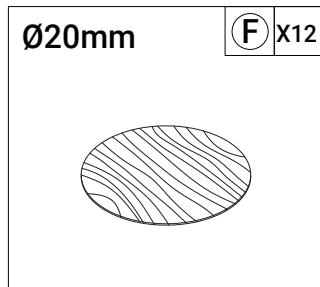
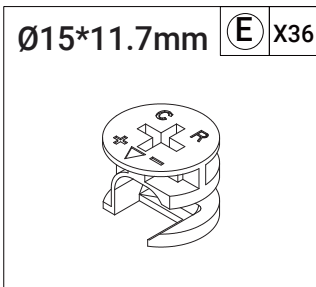
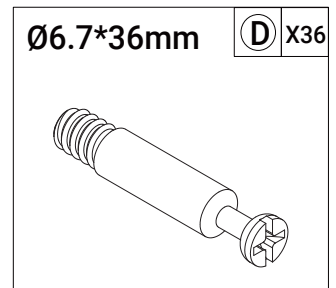
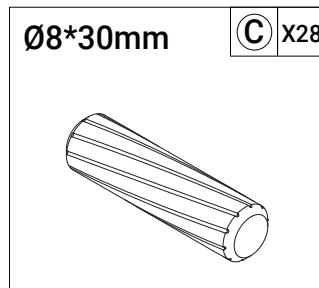
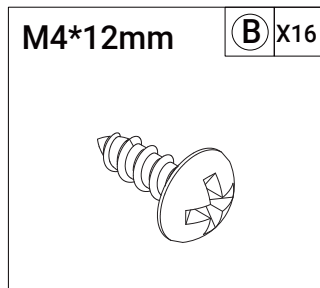
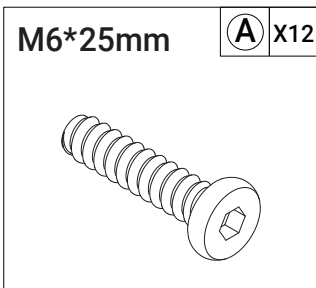

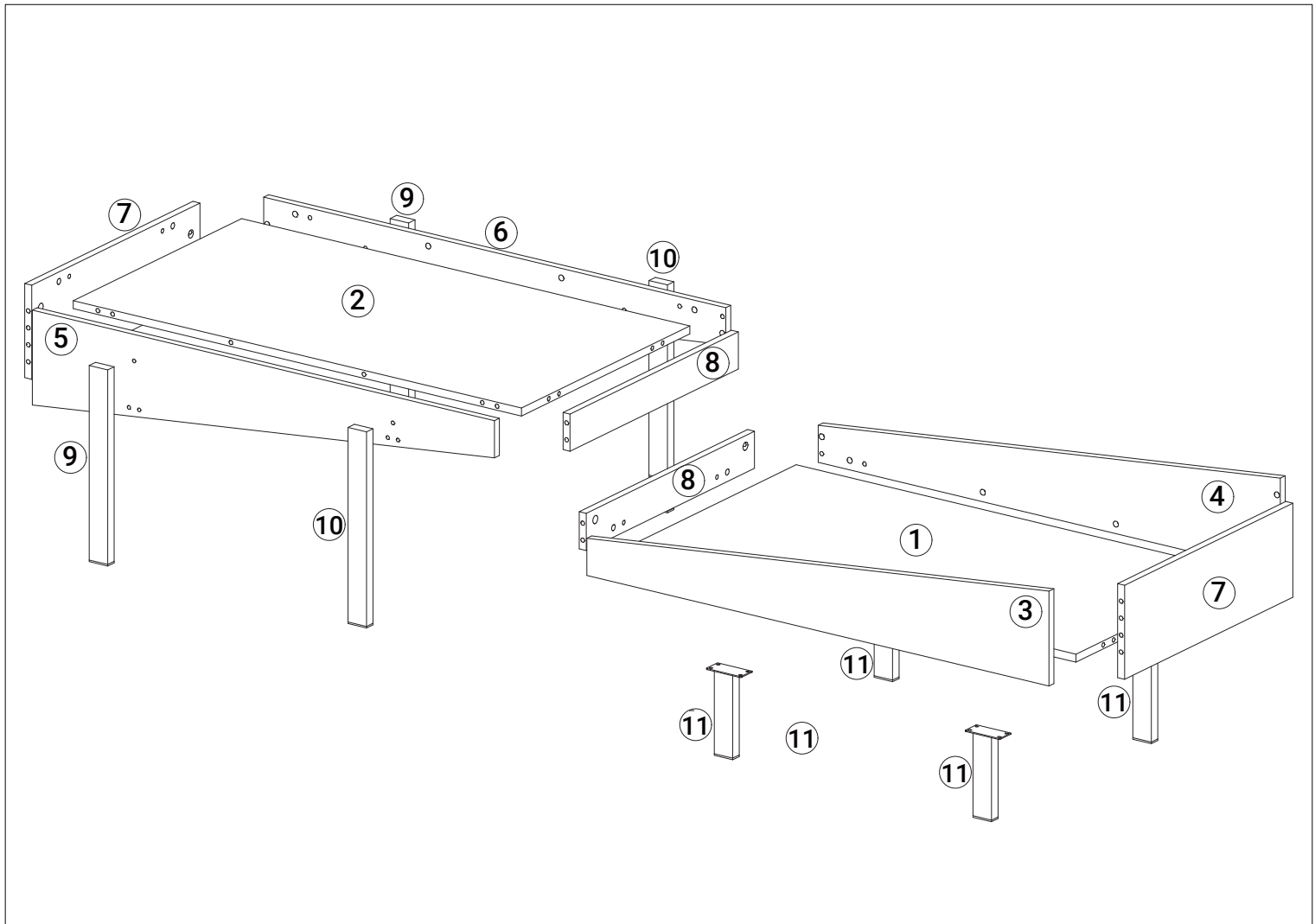

Step 1 | Let's get started. Start by prepping the side boards (3 and 5) with 5 wooden dowels (C) and 7 cam bolts (D) for each one.

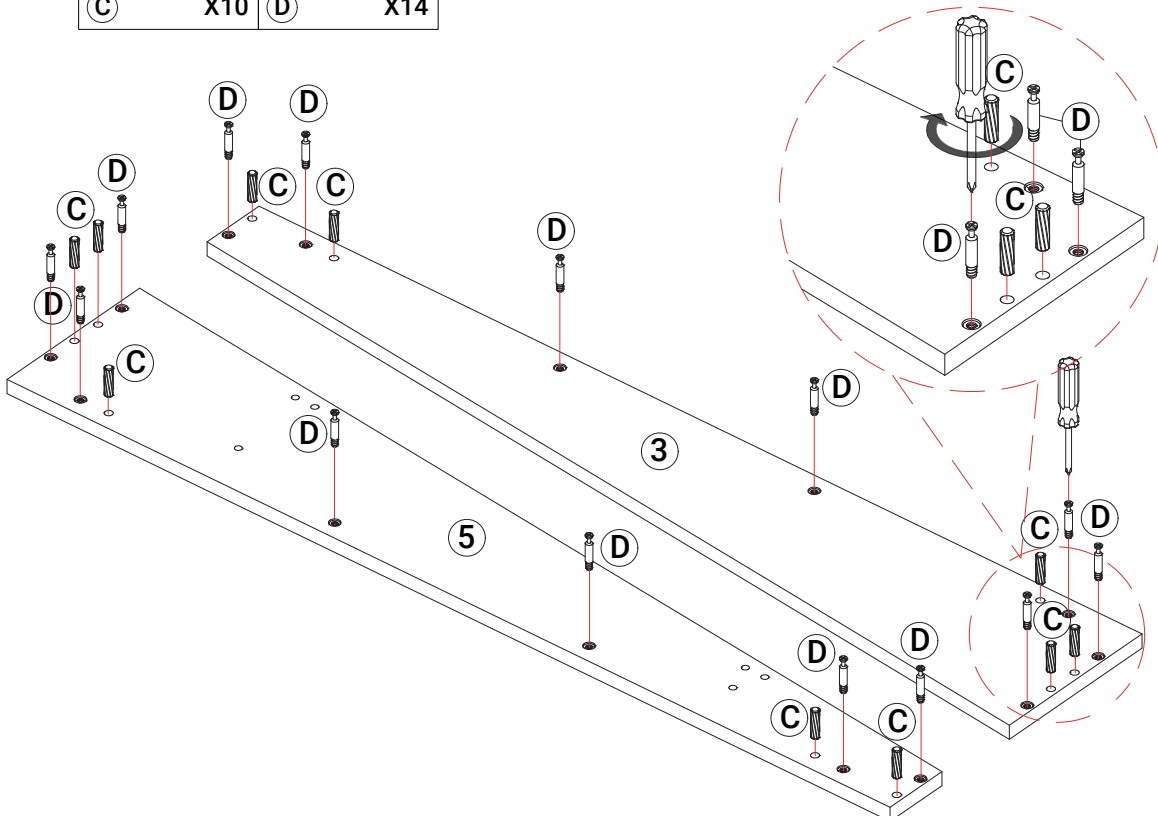
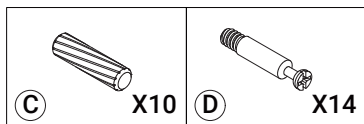

Step 2 | Repeat the previous step, this time with sideboards 4 and 6.

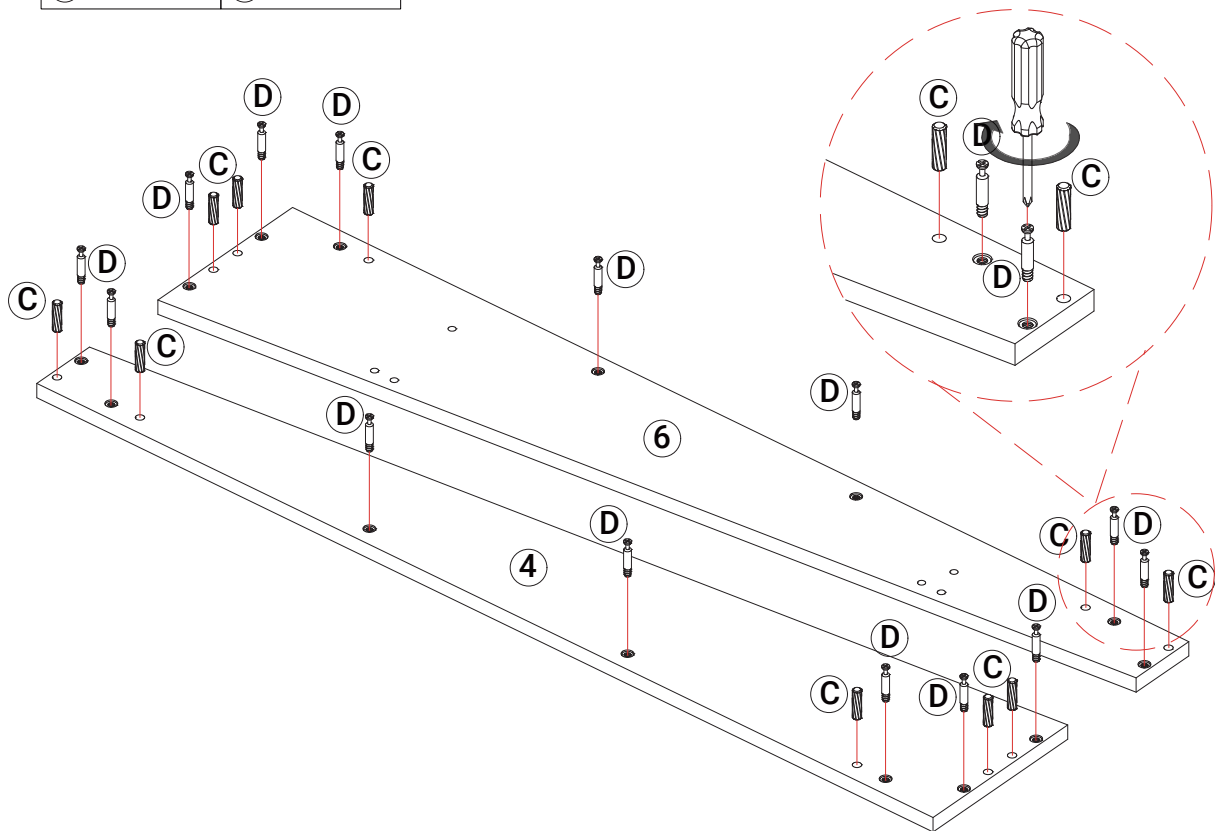
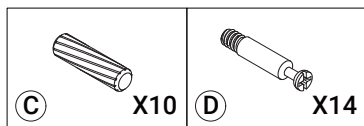

Step 3 | Next, prepare boards 7 and 8 by placing 2 wooden dowels (C) in the inner holes and 2 cam bolts (D) in the outer holes. This step should be completed twice for a total of 4 boards.

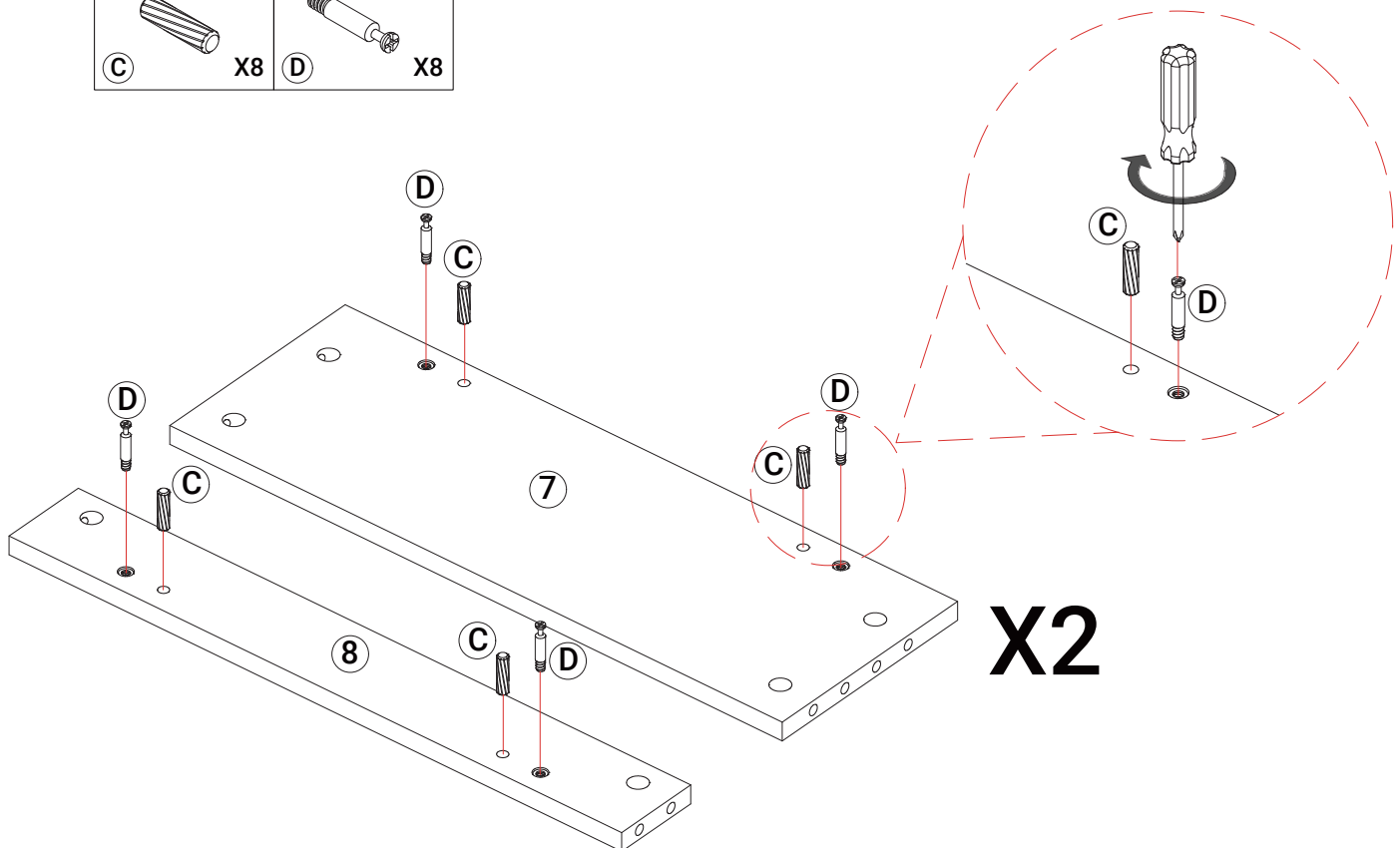
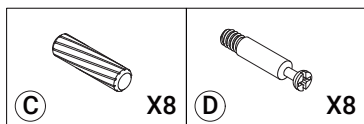

Step 4 | Next, secure the feet (11) to board 1 using 4 screws (B) for each foot.

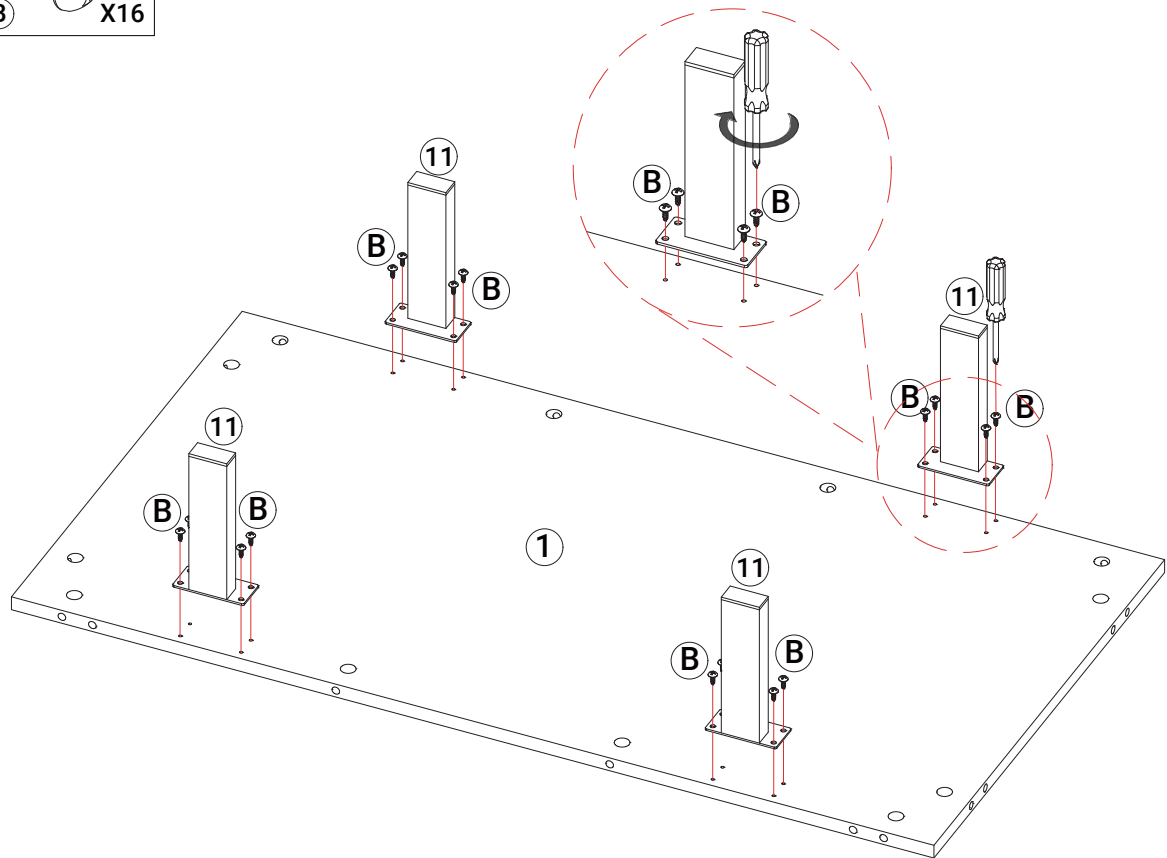
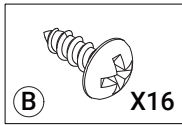

Step 5 | Then add boards 7 and 8 to board 1 by first aligning the cam bolts, then securing in place with the cam locks (E).

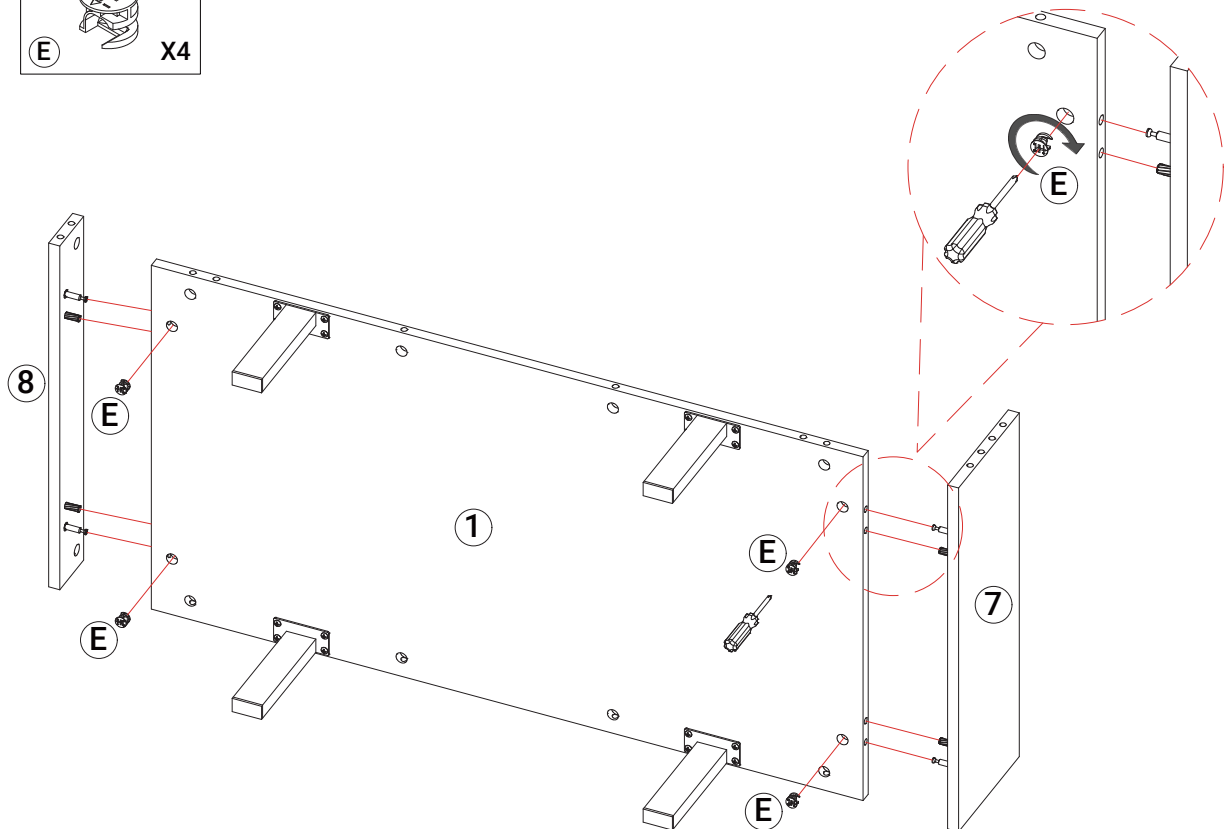
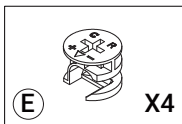

Step 6 | Repeat the last step for the side boards, this time aligning boards 3 and 4 in place and then locking in place with the cam locks (E).

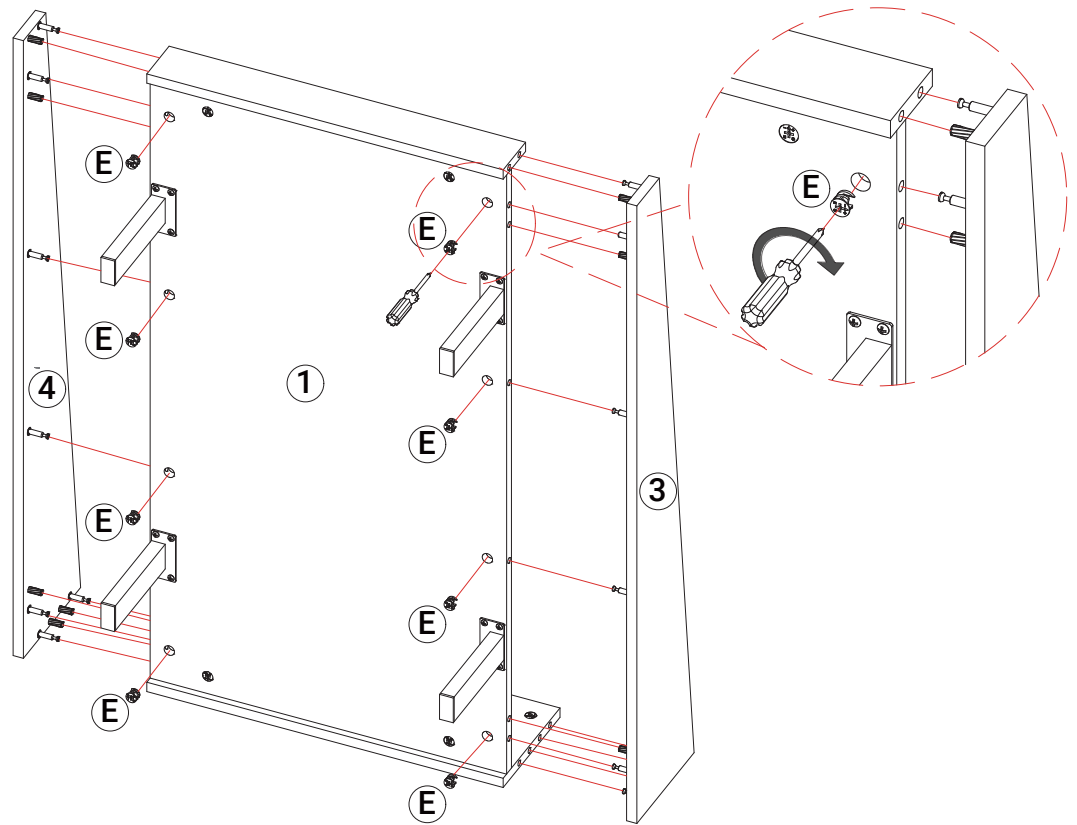
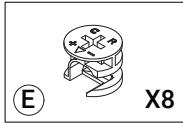

Step 7 | Next, cover all cam locks with the provided texture stickers (G).

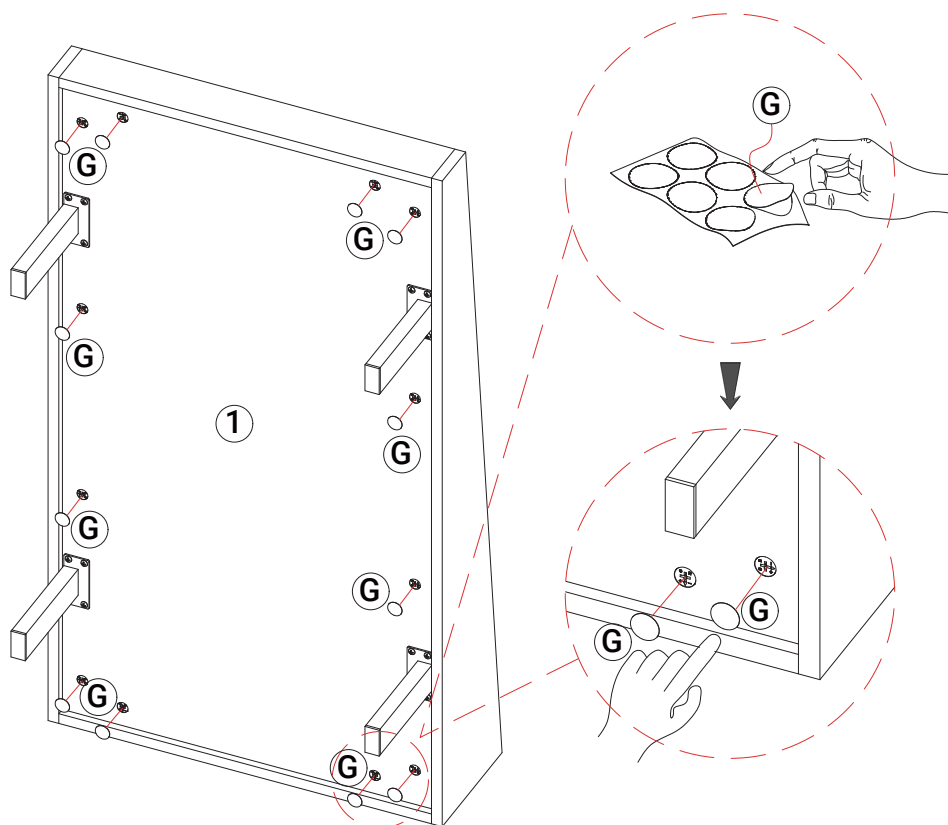
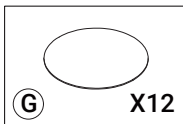

Step 8 | Further secure boards 7 and 8 in place with 6 additional cam locks (E).

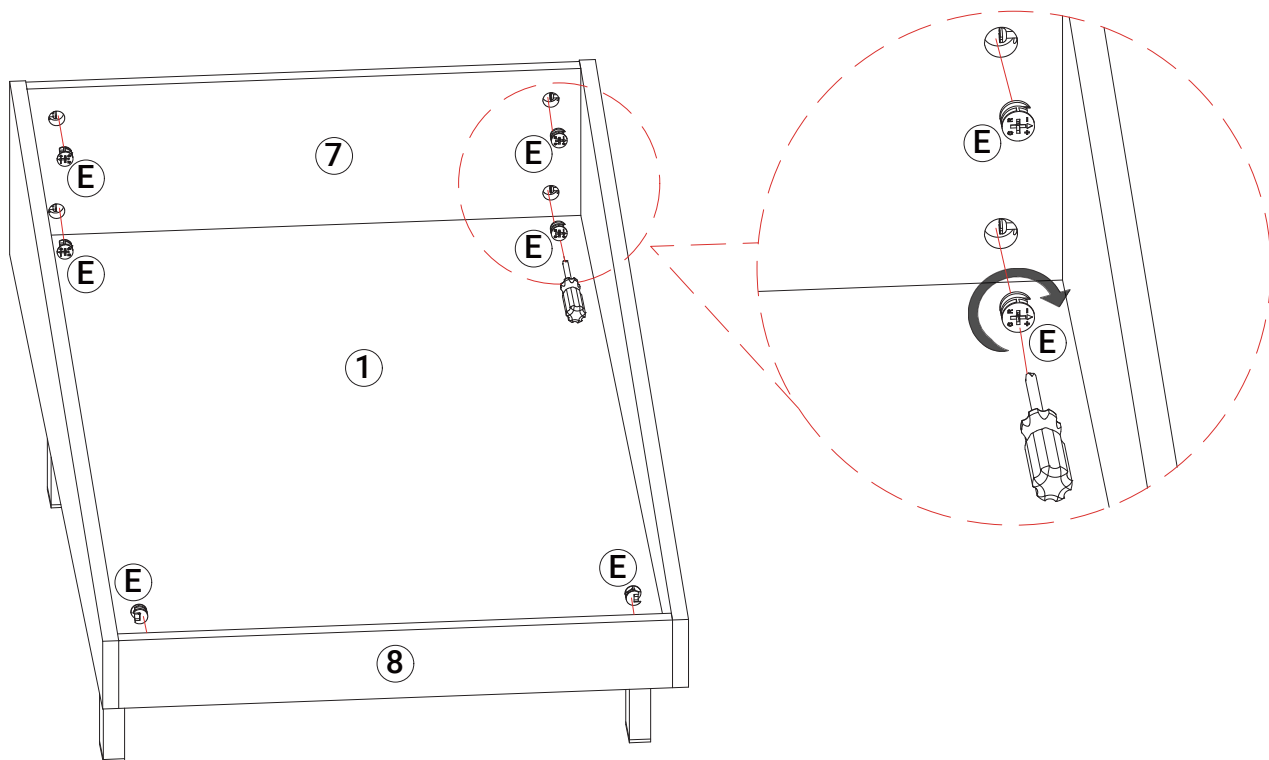
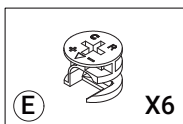

Step 9 | And again, cover the cam locks with the provided texture stickers (F).

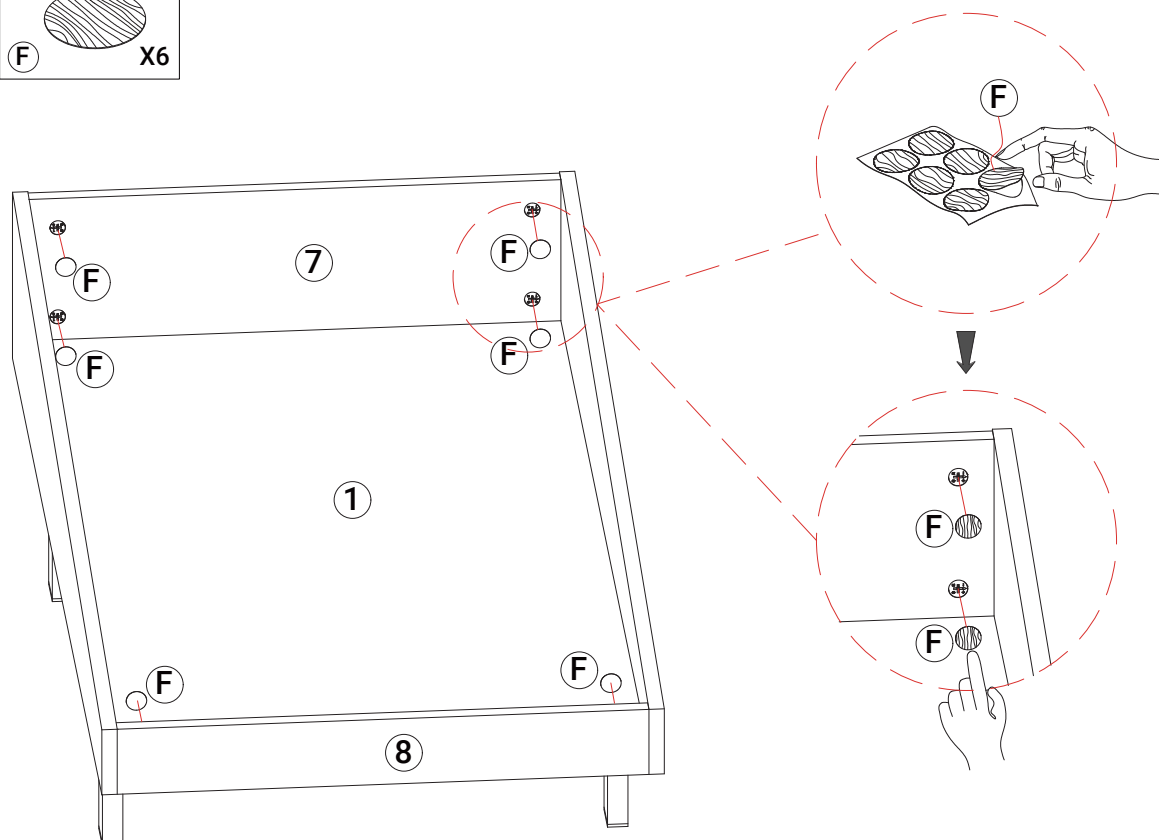
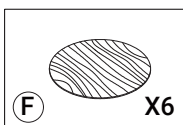

Step 10 | Next, let's build the other table by securing boards 7 and 8 to board 2 using cam locks (E).

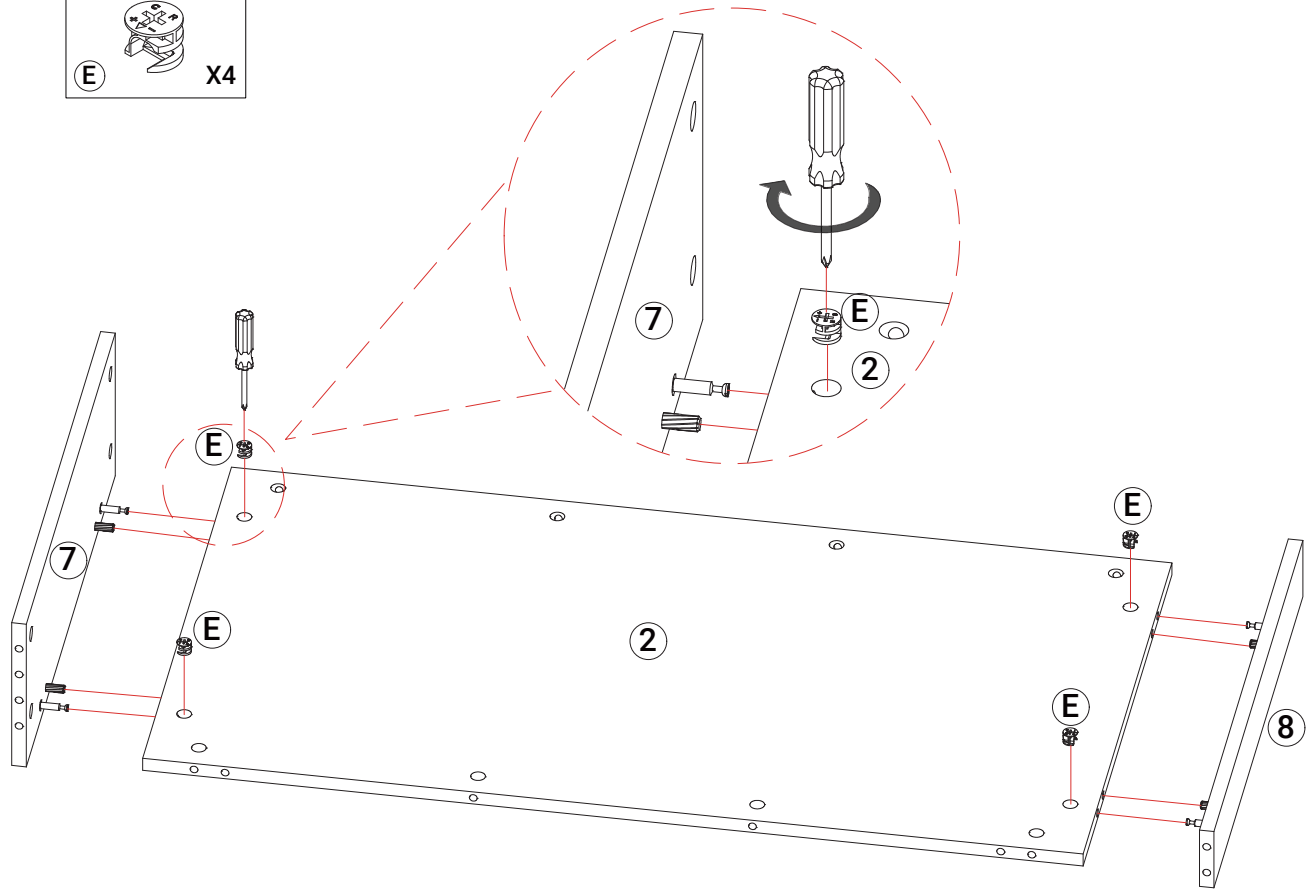
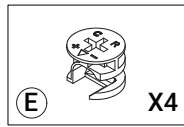

Step 11 | Then add side boards 5 and 6 and again secure with cam locks (E).

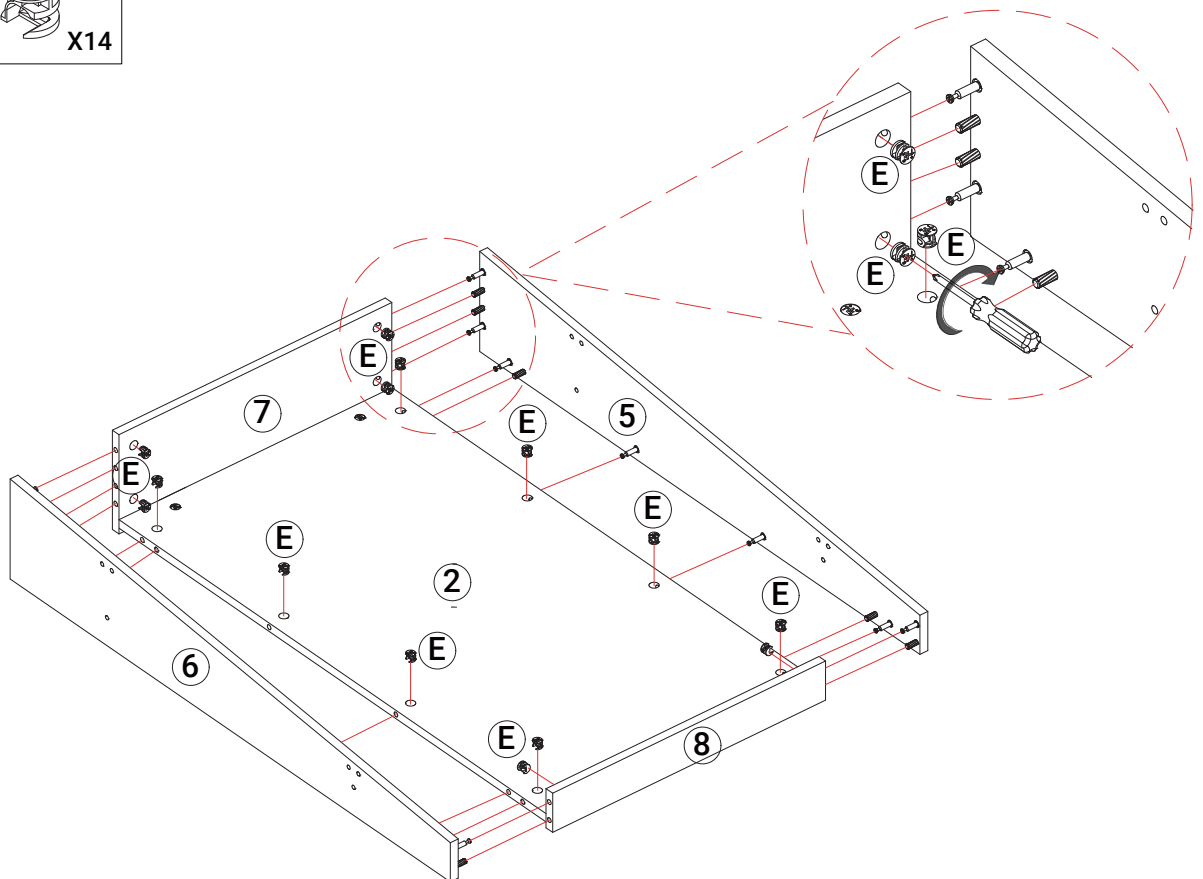
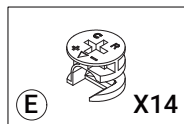

Step 12 | Then add the feet (9 and 10) using 3 bolts (A) for each foot. Note that feet 9 go on the thicker sides of the boards while feet 10 go on the thinner sides.

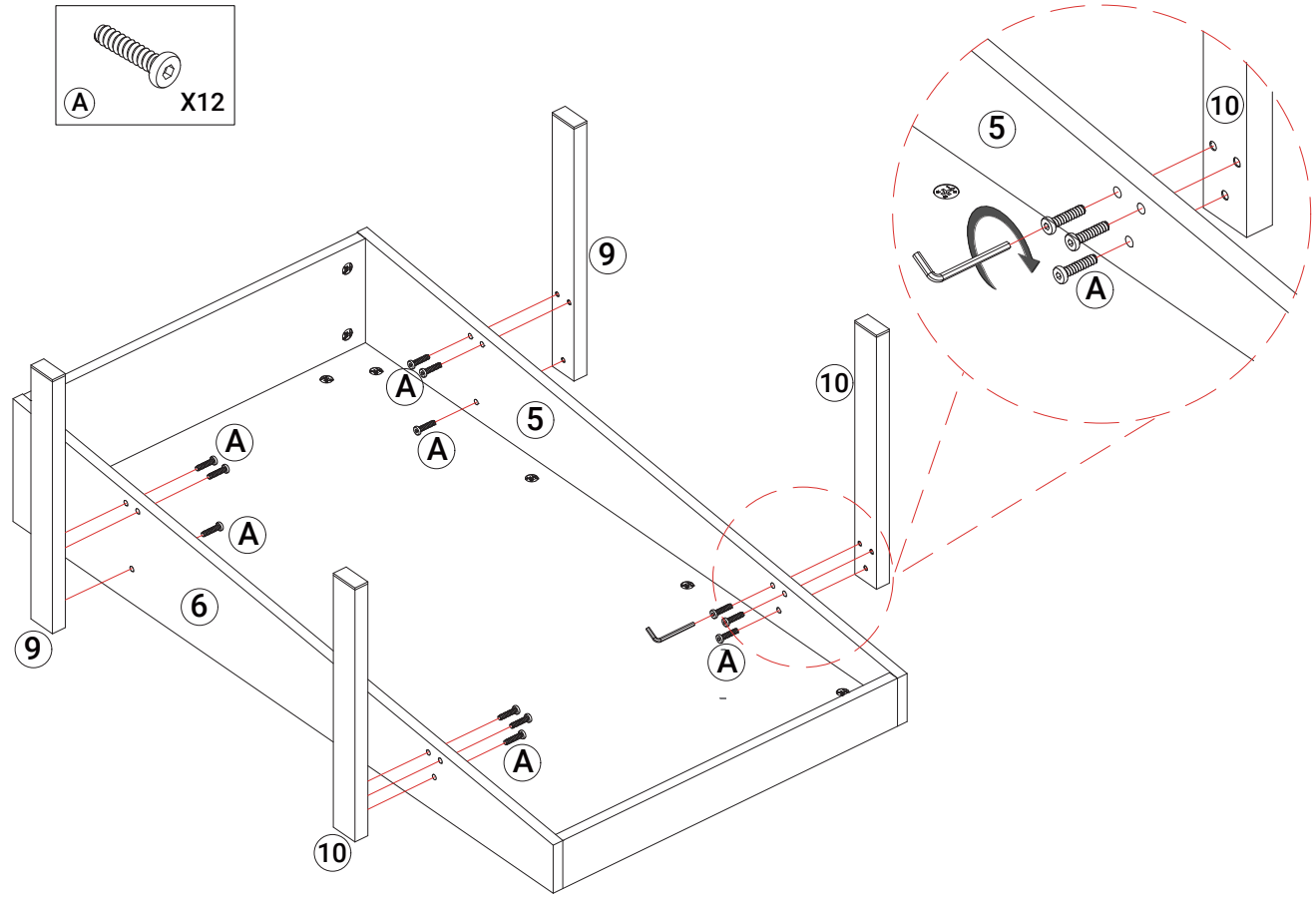

Step 13 | Next, cover the cam locks with the provided texture stickers (F and G).

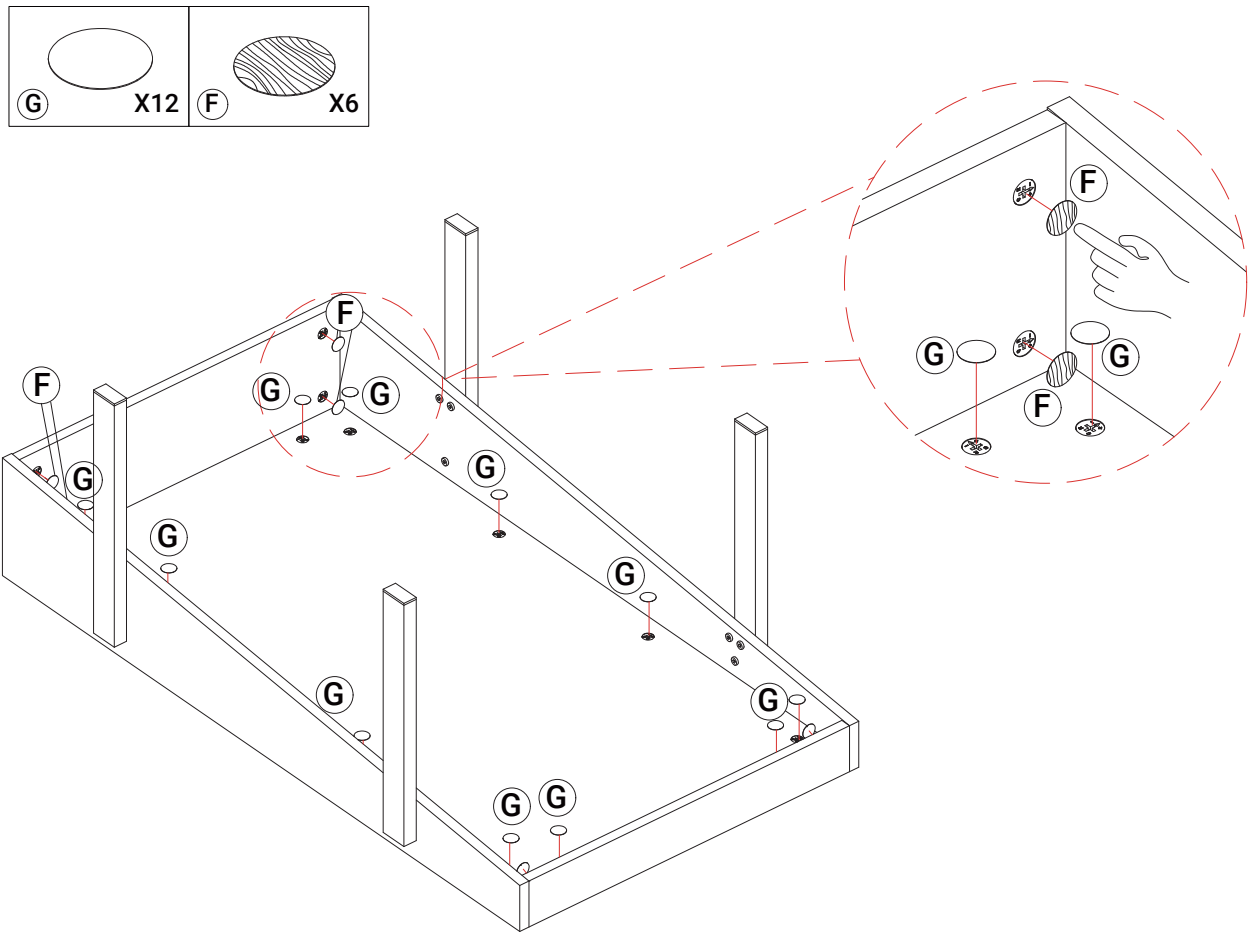

Step 14 | Finally, flip the table upright.

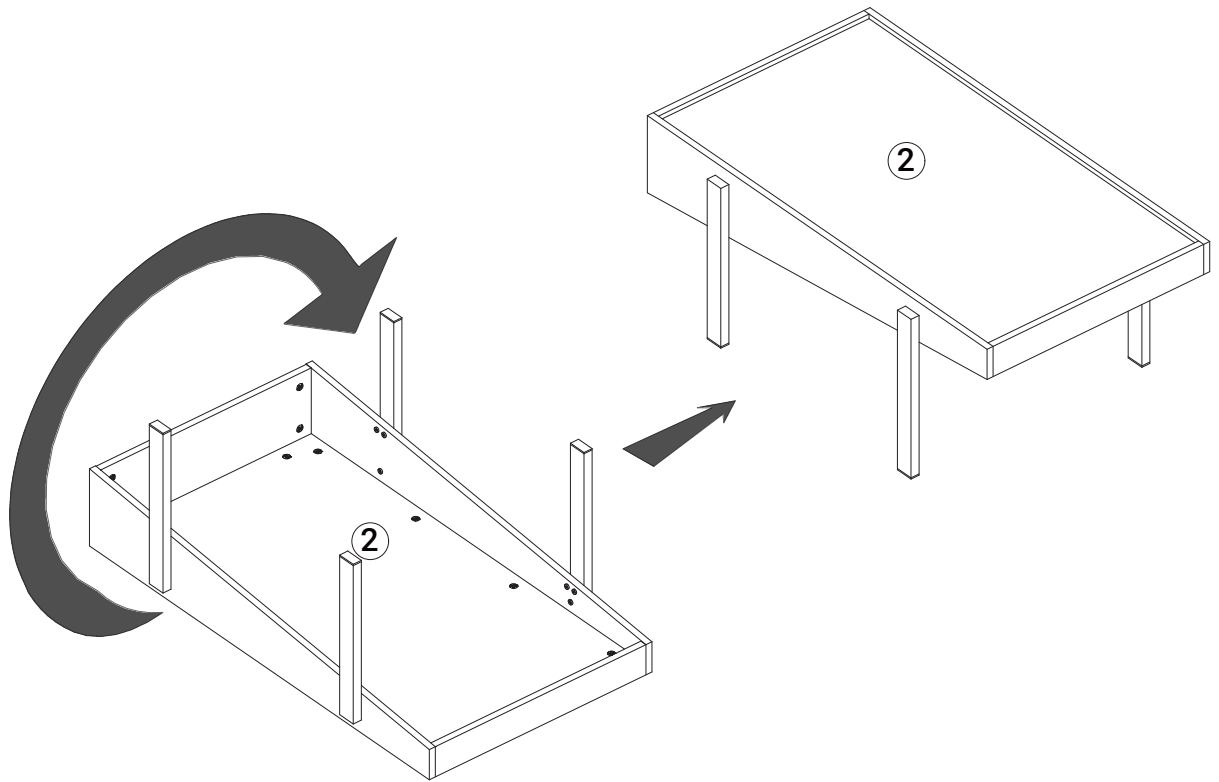

Step 15 | And slide the pieces together.

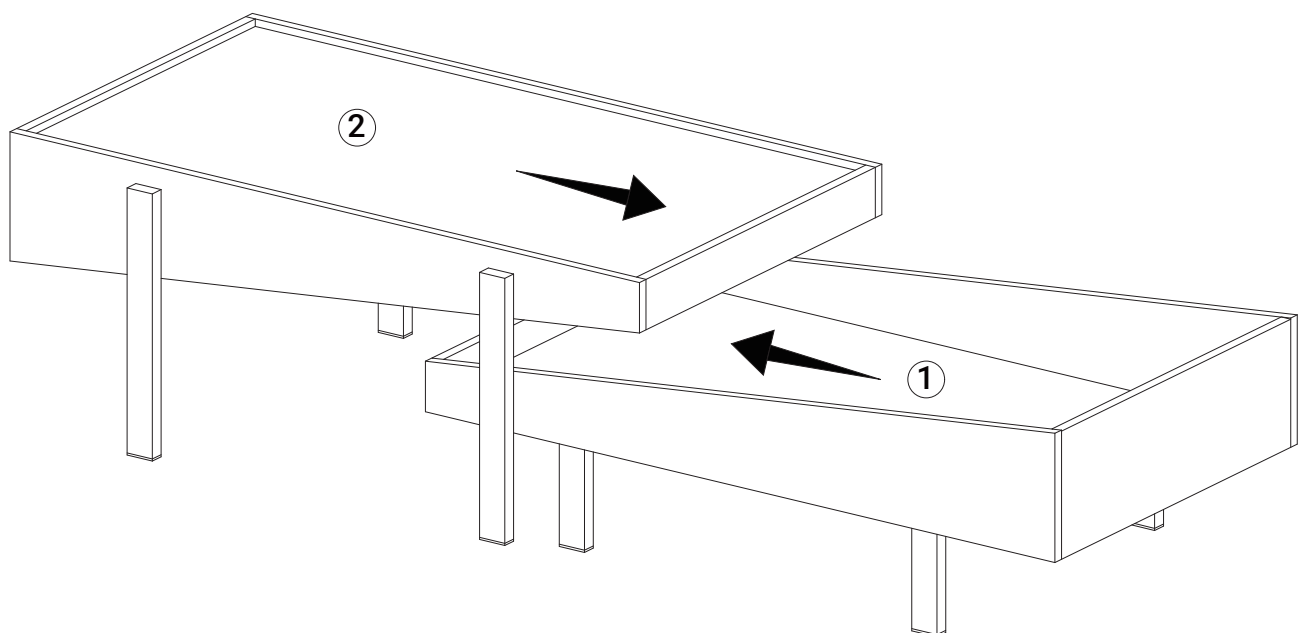

Step 16 |

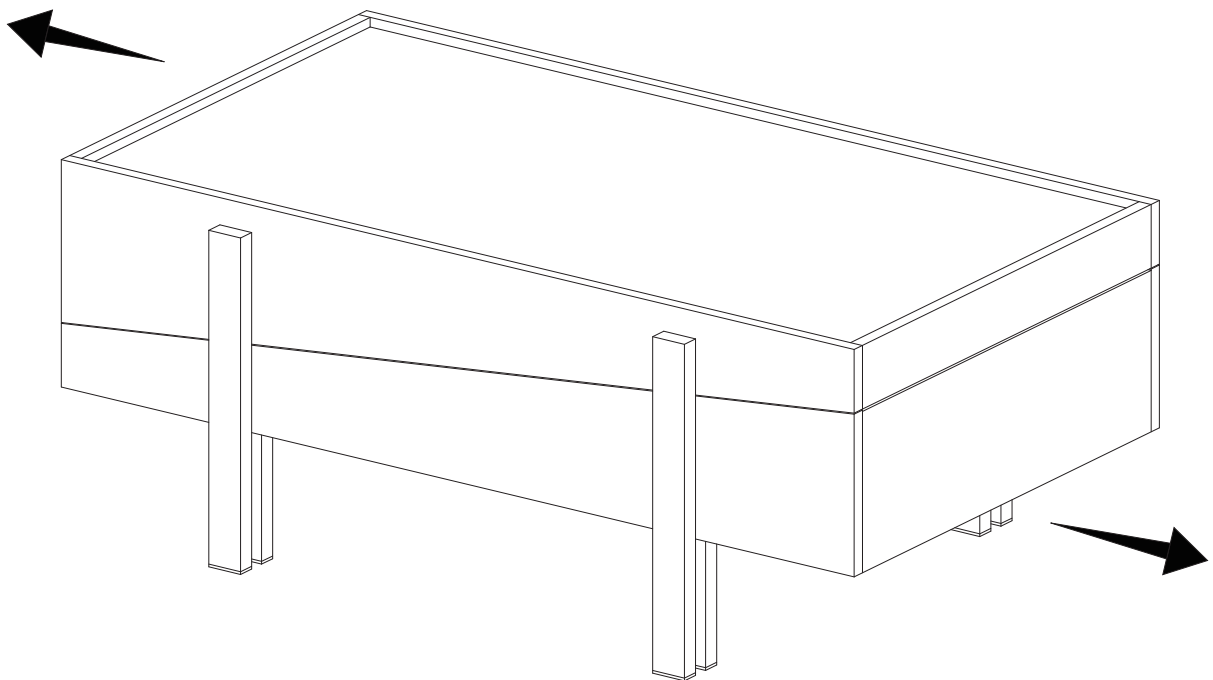
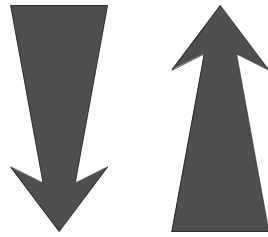
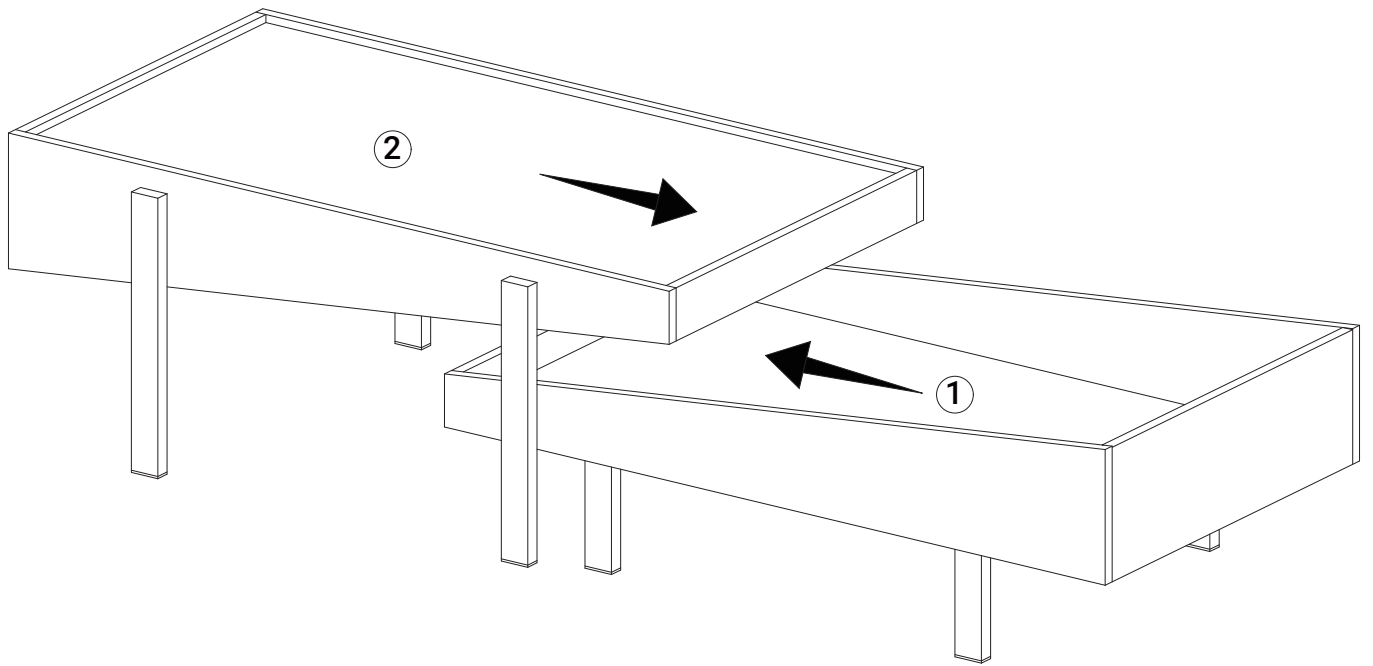

Step 17 | Now that all your hard work is done, it's time to relax and enjoy your craftsmanship!

